



# 750 Motor Club Stock Hatch Championship 2012

## Sporting & Technical Regulations

Final Version - Page 1 of 10 – Issued 06/01/12

### 1: SPORTING REGULATIONS

#### 1.1: TITLE & JURISDICTION:

The **STOCK HATCH CHAMPIONSHIP** is organised and administered by the 750 Motor Club Ltd in accordance with the General Regulations of the Royal Automobile Club Motor Sports Association (incorporating the provisions of the International Sporting Code of the FIA) and these Championship Regulations.

1. **MSA Championship Permit No:** CH2012/R025.
2. **MSA Championship Grade:** D.
3. **Race Status:** Clubman/National B.

#### 1.2: OFFICIALS:

1. **Co-Ordinator:** G.Groombridge, Rose Farm, Upper Oakley, Diss, Norfolk. IP21 4AX. (☎ 01379 741641; ✉ Racing@750mc.co.uk)..
2. **Eligibility Scrutineer:** A.Johnson
3. **Championship Stewards:**  
D.Wells. B.Cottrell. I.Watson.

#### 1.3: COMPETITOR ELIGIBILITY:

1. Entrants must be fully paid up valid membership card holding members of the 750 Motor Club Ltd and possess a valid current year's MSA Entrants Licences.
2. Drivers must be fully paid up valid membership card holding members of the 750 Motor Club Ltd, be registered for the Championship and hold a valid MSA National B (or higher grade) Race Licence or be a professional driver in possession of a valid Licence (featuring an E.U flag) & medical issued by the ASN of a member country of the European Union (MSA Regulation H26.2.1.)
3. All necessary documentation must be presented for checking at all rounds when signing-on.

#### 1.4: REGISTRATION:

1. All drivers must register for the championship by returning the Registration Form with the Registration Fee to the Coordinator prior to the Final Closing date for the first round being entered.
2. The Registration Fee is £110.00 payable to the 750 Motor Club upon registration.
3. Registrations will be accepted from 1<sup>st</sup> January 2012 until the closing date for the last round of the championship.
4. Registration numbers will be the permanent Competition number for the Championship.
5. Change of Registered Vehicle: Should any driver wish to change a vehicle from the one originally registered for the current season, application must be made to the Championship Co-Ordinator (1.2.1) together with a completed Registration Form and Registration Fee. The driver can only change from one make & model registered to another only once in the current season. Ballast awarded will be transferred and points may be transferred subject to the approval of the Championship Coordinator. If it is for the same make and model as the original registration, then the base weight shall be no less than the original. If it is for a different make & model, then the base weight shall be no less than the lightest of that type registered.

#### 1.5: CHAMPIONSHIP ROUNDS:

The **STOCK HATCH CHAMPIONSHIP** will be contested over the following rounds:

Date	Circuit	Round/s
Mar 31/Apr 1	Silverstone	2
Apr 28/29	Brands	2
May 26/27	Cadwell	2
Jun 23/24	Donington	2
Aug 4/5	Anglesey	2 (not Classic SH)
Sep 1/2	Donington	2
Oct 7	Snetterton	2

#### 1.6: SCORING:

It is planned that there will be separate races for Stock Hatch (cars first available for sale in the UK after January 1992) and **Classic Stock Hatch** (cars first available for sale in the UK before January 1992), with awards as per 1.7 below.

1. Points will be awarded, in both of those classes, to classified

finishers listed in the final results as follows:- 1<sup>st</sup> 50; 2<sup>nd</sup> 47; 3<sup>rd</sup> 45; then reducing by 1 point per place down to 3 points for 45<sup>th</sup>. All other classified finishers 2 points; non-finishers 1 point. Fastest lap (in each class) 1 point.

2. The totals from all qualifying rounds **run** (excluding any races which are abandoned and which are not replaced) less 2 will determine the final championship points positions.
3. **Ties for end-of-season award winning places shall be resolved, when more than one competitor have equal totals, by taking into account the highest number of 1<sup>st</sup> places, 2<sup>nd</sup> places etc from the races they are counting as their best total (i.e. their finishing position in dropped rounds do not get taken into account). If that fails to find a winner their highest or subsequent highest dropped scores will be added to their existing total score until a conclusive result is found.**

#### 1.7: AWARDS:

1. All awards are to be provided by the Organising Club unless agreed otherwise.
2. Per Round: 1<sup>st</sup>, 2<sup>nd</sup> & 3<sup>rd</sup> in both classes.
3. Championship: Subject to a minimum of 5 race starts, trophies to:-  
1<sup>st</sup>, 2<sup>nd</sup>, 3<sup>rd</sup>, 4<sup>th</sup>, 5<sup>th</sup> & 6<sup>th</sup> overall in both classes.  
Highest placed driver who has not previously held an MSA Car Race Licence – both classes.  
Best prepared car – both classes.
4. Bonuses:  
Per Round: not applicable.  
Championship: **not applicable**
5. Presentations: Garlands and Trophies are to be provided for presentation at the end of each race.
6. Entertainment Tax Liability. Not applicable.
7. Title to all Trophies: In the event of any Provisional Results or Championship Tables being revised after any provisional presentations and such revisions affecting the distribution of any awards the Competitors concerned must return such awards to the 750 Motor Club Competitions Secretary in good condition within 7 days.

### 2: SPORTING REGULATIONS - JUDICIAL PROCEDURES

**Rounds & Championship:** In accordance with Section C of the current year's MSA Yearbook and 4.2. of these regulations.

### 3: SPORTING REGULATIONS –

#### CHAMPIONSHIP RACE MEETINGS & RACE PROCEDURES

#### 3.1: ENTRIES:

1. Competitors are responsible for sending in correct and complete entries with the correct entry fees prior to the close of entry dates as per the entry forms.
2. Incorrect or incomplete entries (including driver to be nominated entries) are to be held in abeyance until they are complete and correct and the date of receipt for acceptance of entry purposes shall be the date on which the Secretary of the Meeting receives the missing or corrected information or fee.
3. Any withdrawal of entry or driver/car changes made after acceptance of any entry must be notified to the Secretary of the Meeting in writing. If driver/vehicle changes are made after the publication of Entry Lists with Final Instructions, the Competitor concerned will be accepted in accordance with D25.1.12.
4. The entry fee for each round shall be as per the Supplementary Regulations.
5. In the event of any rounds being oversubscribed the Organising Club may, in liaison with the Championship Coordinator, at their discretion run Qualification races. For Qualification Race procedures see 3.13 of these regulations.
6. Reserves are to be nominated on the Final List of Entries published with the Final Instructions or Amendment Sheet Bulletins. Reserves will practice and replace non-qualified (including drivers practising out-of-session or qualifying by virtue of having raced at the circuit within the previous 12 months), withdrawn or retired entries in Reserve Number order irrespective of class. If reserves are given Grid



# 750 Motor Club Stock Hatch Championship 2012

## Sporting & Technical Regulations

Final Version - Page 2 of 10 – Issued 06/01/12

Places prior to issue of the first Grid Sheets for any round, the times set in practice shall determine their grid positions. If Reserves are given places after publication of the grid sheet and prior to cars being collected in the Official "Assembly Area" they will be placed at the rear of the grid and be started without any time delay. Otherwise they will be held in the Pitlane and be released to start the race after the last car to start the Green Flag Lap or last car to take the start has passed the startline or pitlane exit whichever is the later. Such approval to start MUST be obtained from the Clerk of Course.

**7. Acceptance of Entries:** Up to Closing Day, Race meeting organisers may accept up to the maximum number of starters permitted on the Track Licence for the circuit ("the maximum"). If entries received by closing day exceed the maximum, selection will be made in order of receipt. Those in excess of the maximum and up to 20% more will be treated as 'reserves'. If the maximum has not been reached by closing day, entries received after that date will be accepted strictly in order of receipt until the maximum is reached.

### 3.2: BRIEFINGS:

Organisers must notify competitors of the times and locations for all briefings in the Final Instructions or Official Race Day Bulletins for the meetings. Competitors must attend all briefings.

### 3.3: PRACTICE:

Practice sessions will be as per MSA Regulations Q4.5. Should any practice session be disrupted, the Clerk of the Course shall not be obliged to resume the session or re-run sessions to achieve the championship criteria and the decision of the Clerk of the Course shall be final.

### 3.4: QUALIFICATION:

Each driver should complete a minimum of 3 laps practice in the car to be raced and in the correct session in order to qualify for selection and order of precedence as set out in MSA regulations Q4.5. Drivers practising out-of-session or qualifying by virtue of having raced at the circuit within the previous 12 months will be placed at the back of the grid. The Clerk of the Course and/or Stewards of the Meeting shall have the right to exclude any driver whose practice times or driving are considered to be unsatisfactory - as per MSA Regulation Q4.5.

### 3.5: RACES:

The standard minimum scheduled race distance shall be 13 minutes plus 1 lap but should any race distance be reduced at the discretion of the Clerk of the Course or Stewards of the Meeting, it shall still count as a full points-scoring round.

### 3.6: STARTS:

Unless modified by the Organising Club's Standing Regulations, the following regulations shall apply:-

1. There will be a minimum elapsed period of 3 minutes from cars being released from the Assembly Area to the start of the race or, if applicable, the green flag lap.

2. Start Procedure: In normal circumstances there will be no green flag lap. A 'two minute' board will be shown on the startline; engines should be started at this stage and the grid cleared of any pit crew. A 'one minute' board will be shown, followed by a '30 second' board; a '5 second' board will be displayed; approximately 5 seconds after this board is withdrawn the red lights will be switched on; after between 2 seconds and 7 seconds they will be switched off to start the race. In the event of the failure of these lights a National Flag will be used to start the race.

In circumstances where a green flag is used, it will be waved from the startline to commence the green flag lap. The pole position driver should set a reasonable pace during this lap and slow down on approaching the startline to allow the grid to close up. Drivers should resume their correct grid positions with the minimum of delay. Any drivers unable to start the green flag lap or start the race are required to indicate their situation as per MSA regulation Q12.13.2. Drivers may make up any lost grid position during this green flag lap, BUT any drivers unable to maintain grid position to the extent that ALL other cars are ahead of them, may complete the green flag lap but MUST

remain at the rear of the last row of the grid but ahead of any cars to be started with a time delay.

A '5 second' board will be displayed when the grid is stationary. Approximately 5 seconds after this board is withdrawn the red lights will be switched on; after between 2 seconds and 7 seconds they will be switched off to start the race. In the event of the failure of these lights a National Flag will be used to start the race.

3. Any car removed from the grid or driven into the pits after leaving the Assembly Area shall be held in the pitlane and may start the race after the last car to take the start from the grid has passed the startline or pit exit lane whichever is the later.

4. Excessive weaving to warm-up tyres - using more than 50% of the track width - and falling back in order to accelerate and practice starts, is prohibited.

### 3.7: RACE STOPS:

As per Q5.4 to 5.4.3. of the current MSA Yearbook.

### 3.8: RE-SCRUTINY:

All vehicles reported involved in contact incidents during races or practice must be re-presented to the Scrutineers before continuing in the races or practice.

### 3.9: PITS AND PITLANE SAFETY:

1. Pits: Entrants must ensure that the MSA, Circuit Management and Organising Club Safety Regulations are complied with at all times.

2. Pitlane: The outer lane or lanes are to be kept unobstructed to allow safe passage of cars at all times. The onus shall be on all drivers to take all due care and drive at minimum speeds in pit lanes.

3. Refuelling may only be carried out in accordance with the MSA Regulation Q13, Circuit Management regulations and the SRs or Final Instructions issued for each Circuit/Meeting.

### 3.10: RACE FINISHES:

After taking the chequered flag drivers are required to: - Progressively and safely slow down, remain behind any competitors ahead of them, return to the pitlane entrance as instructed, comply with any directions given by Marshals or Officials and to keep their helmets on and harnesses done up while on the circuit or in the pitlane.

### 3.11: RESULTS:

All Practice timesheets, grid sheets and Race Results are to be deemed PROVISIONAL until all vehicles are released by Scrutineers after post-practice/race scrutineering and/or after completion of any judicial or technical procedures.

### 3.12: TIMING MODULES:

The 750 Motor Club utilises AMB transponder-based timing and competitors **must** have a compatible transponder fitted and **working** and advise the race organisers of its number prior to the event. The transponder is a TRANX 260 Direct Powered and is available from HS Sports Ltd – 01260 275708.

### 3.13: QUALIFICATION RACES:

If on closing date the number of entries received is appreciably more than the maximum number of starters permitted, the race meeting organisers will endeavour if feasible within the timetable, to run practice sessions and races to accommodate all entries, but are not obliged to do so. The grid for the heat will be filled by the slowest drivers from practice/s, the remainder forming the front part of the grid for the final. Spaces on the back of the grid for the final will be filled by the top classified finishers in the heat. If there are two practice sessions and the track conditions for them are significantly different, the grid for the heat will be filled by taking alternately from each session the slowest drivers until the grid is full. If three practice sessions/races are to be run, the selection procedure will be stated in the Final Instructions.

### 3.14: CANCELLED/ABANDONED RACES:

There may be occasions when, due to circumstances on the day, a scheduled race is not run, a race meeting is abandoned or the circuit curfew is reached. The 750 Motor Club will use its best endeavours to



# 750 Motor Club Stock Hatch Championship 2012

## Sporting & Technical Regulations

Final Version - Page 3 of 10 – Issued 06/01/12

find space in another race meeting in the same season in order to run a replacement championship round; preference will be given to a race meeting where the affected formula is already scheduled to race. No change of vehicle or class will be permitted without the permission of the Championship Stewards and then only in exceptional circumstances.

### **A: The qualifying session for a race/s does not take place.**

Entry for the replacement race will be restricted to those who were 'signed on' for the race which is being replaced. A separate qualifying session will normally be held. If no space can be found for a replacement race, the number of championship scoring rounds will be adjusted accordingly.

### **B: The qualifying session for a race/s has taken place, but the race did not come under starters orders.**

Entry for the replacement race will be restricted to those who were qualified for the race which is being replaced; the grid for the cancelled race will be used for the replacement race. If no space can be found for a replacement race, the number of championship scoring rounds will be adjusted accordingly.

C & D below apply if a race is 'red flagged' once.

### **C: A race is 'red flagged' before the leader has completed two laps, but there is no time available to restart the race.**

Entry for the replacement race will be restricted to those who would have been able to restart the race which is being replaced; the grid for the cancelled race will be used for the replacement race. If no space can be found for a replacement race, the number of championship scoring rounds will be adjusted accordingly.

### **D: A race is 'red flagged' after the leader has completed two laps but less than 75% of its duration, but there is no time available to implement MSA regulation Q5.4.2.**

If the Clerk of Course decides that a replacement race should be run it will be in accordance with MSA regulation Q5.4.2. If no space can be found for a replacement race, a result will be declared retrospectively based on the order of crossing the finish line at one lap less than at the first time of the showing of the red flag and only cars which were under their own power at the showing of the red flag will be classified.

**If a race is 'red flagged' twice** and the second red flag is before the leader has completed two laps, the Clerk of Course may decide to rerun the race on the same day subject to circuit curfew but is not obliged to do so. If the decision is taken that it should not be rerun on the day or it cannot because of circuit curfew, it will be considered an abandoned race and the number of championship scoring rounds will be adjusted accordingly.

### **3.15: Additional Sporting Regulations issued for the Championship.**

1. Any driver competing in the Championship may be called before a meeting of the Championship Stewards who, at their discretion, may take further action that could include exclusion from part or all of the Championship.
2. The Organisers will use any evidence available to them to request that the Championship Stewards investigate any drivers who are deemed to show poor driving standards or bring the championship into disrepute in any such manner through on and / or off track incidents. This will include any complaints made officially by registered competitors.
3. Championship Stewards are also empowered to consider any request from the Championship co-ordinator to penalise any Competitor for any breach of Championship regulations and, after holding a formal hearing if they deem it necessary, to impose a penalty in accordance with MSA Regulation C.2.1.1 (subject to the rights of appeal provided for in Section C).
4. One or more of the following may be imposed by the Championship Stewards as appropriate:
  - a) Reprimand.

- b) Fine. This may be also applied in the case of a driver receiving three reprimands from the Championship Stewards in one season.
- c) Time Penalty.
- d) Suspension from all or part of the Championship. This may also be applied in the case of a driver receiving two fines from the Championship Stewards in one season.
- e) Disqualification.

## **4: CHAMPIONSHIP RACE PENALTIES:**

### **4.1: INFRINGEMENT OF TECHNICAL REGULATIONS:**

1. Arising from post-practice scrutineering or judicial action: Should a vehicle be found ineligible, the Clerk of Course will impose the penalty set out in MSA Regulation C3.3.
2. Arising from post-race scrutineering or judicial action: Should a vehicle be found ineligible, the Clerk of Course will impose the penalties set out in MSA Regulation C3.5.1 a & b and may impose the penalty set out in MSA Regulation C3.5.1 c. Technical infringements may be referred to the Championship Stewards for further action/penalties.

### **4.2: INFRINGEMENT OF NON-TECHNICAL MSA REGULATIONS and the Sporting Regulations issued for the Championship:**

1. In the case of a driver being excluded from a race, the Clerk of Course will impose the penalties set out in MSA Regulation C3.5.1 a & b and may impose the penalty set out in MSA Regulation C3.5.1 c.
2. In order to maintain standards of conduct, the Championship Organisers will monitor all Officials/Observers reports of adverse behaviour at race meetings. If any individual is included on two such reports during one racing season the Championship Organisers will request the Clerk of Course at future race meetings to consider specific observation of that driver's conduct.
3. The Clerk of Course may impose a 'Stop-Go' or 'Drive through' penalty during a race, in accordance with MSA Regulation Q12.6.
4. Any Competitor who is penalised under the Championship Sporting Regulations at any stage of a Championship event and receives an allocation of penalty points on their race licence in accordance with MSA regulations, will receive a grid slot penalty at the next round in which they compete following the allocation of penalty points, equal to the number of penalty points which were allocated. Double headers will be considered as two separate rounds; however if the decision to allocate penalty points is delayed such that further round/s of the Championship have taken place since the offence, the grid slot penalty will be implemented at the next round in which they compete after the allocation of the penalty points. The penalty will mean that a Competitor will be moved back grid slot places from their grid position (e.g. if a Competitor with a three grid slot penalty had a qualifying time that was good enough for pole position then the Competitor will start fourth on the grid). If for any reason the imposition of this grid penalty is impractical (such as the competitor's qualifying time, starting from the pitlane etc) or the offence occurs at the final meeting of the season, a time penalty of 5 seconds will be added to the elapsed race time of the competitor.
5. Additional specific Championship penalties as per 3.15 of these regulations.

## **4: CHAMPIONSHIP RACE PENALTIES:**

### **4.1: INFRINGEMENT OF TECHNICAL REGULATIONS:**

1. Arising from post-practice scrutineering or judicial action: Should a vehicle be found ineligible, the Clerk of Course will impose the penalty set out in MSA Regulation C3.3.
2. Arising from post-race scrutineering or judicial action: Should a vehicle be found ineligible, the Clerk of Course will impose the penalties set out in MSA Regulation C3.5.1 a & b and may impose the penalty set out in MSA Regulation C3.5.1 c. Technical infringements may be referred to the Championship Stewards for further action/penalties.
3. Additional specific Championship penalties: See 4.2.2.



# 750 Motor Club Stock Hatch Championship 2012

## Sporting & Technical Regulations

Final Version - Page 4 of 10 – Issued 06/01/12

### 4.2: INFRINGEMENT OF NON-TECHNICAL MSA REGULATIONS and the Sporting Regulations issued for the Championship:

1. In the case of a driver being excluded from a race, the Clerk of Course will impose the penalties set out in MSA Regulation C3.5.1 a & b and may impose the penalty set out in MSA Regulation C3.5.1 c.
2. In order to maintain standards of conduct, the Championship Organisers will monitor all Officials/Observers reports of adverse behaviour at race meetings. If any individual is included on two such reports during one racing season the Championship Organisers will request the Clerk of Course at future race meetings to consider specific observation of that driver's conduct.
3. The Clerk of Course may impose a 'Stop-Go' or 'Drive through' penalty during a race, in accordance with MSA Regulation Q12.6.
4. Any Competitor who is penalised under the Championship Sporting Regulations at any stage of a Championship event and receives an allocation of penalty points on their race licence in accordance with MSA regulations, will receive a grid slot penalty at the next round in which they compete following the allocation of penalty points, equal to the number of penalty points which were allocated. Double headers will be considered as two separate rounds; however if the decision to allocate penalty points is delayed such that further round/s of the Championship have taken place since the offence, the grid slot penalty will be implemented at the next round in which they compete after the allocation of the penalty points.

The penalty will mean that a Competitor will be moved back grid slot places from their grid position (e.g. if a Competitor with a three grid slot penalty had a qualifying time that was good enough for pole position then the Competitor will start fourth on the grid). If for any reason the imposition of this grid penalty is impractical (such as the competitor's qualifying time, starting from the pitlane etc) or the offence occurs at the final meeting of the season, a time penalty of 5 seconds will be added to the elapsed race time of the competitor.

## 5: TECHNICAL REGULATIONS

### 5.1: INTRODUCTION:

- a) The following Technical Regulations are set out in accordance with the MSA specified format and it should be clearly understood that if the following texts do not clearly specify that you can do it, you must work on the principle that you cannot. The fact that some modifications are mentioned as prohibited does not imply that others are allowed.
- b) **STANDARD:** The word 'standard' used within these technical regulations as a description of components is to be interpreted as per 'Standard Part' defined in Section B – Nomenclature & definitions in the MSA Blue Book. Checking will be by comparison to spare parts supplied by the manufacturer's official agent or by any other means necessary to ensure compliance. It applies to the specified component/s from the manufacturer's parts list for the model / engine shown on the entry form or registration form. No modifications permitted beyond the repair or adjustment processes specifically specified by the manufacturers' workshop manual or microfiche.' Checking will be by comparison to spare parts supplied by the manufacturer's official agent or by any other means necessary to ensure compliance. Where specifications for parts (e.g camshaft, final drive, gear ratios, anti-roll bars etc) are stated within table 6.3 of these regulations, they are mandatory for that make and model of car.
- c) **STANDARD PATTERN:** The words 'standard pattern' used within these technical regulations as a description of components is to be interpreted as per 'Standard Pattern Part' defined in Section B – Nomenclature & definitions in the MSA Blue Book. Checking will be by comparison to spare parts supplied by the manufacturer's official agent or by any other means necessary to ensure compliance.
- d) Homologation papers, including VO, VK or ES extensions, will not be accepted as proof of specification of any components.

### 5.2: GENERAL DESCRIPTION:

- 1) The **STOCK HATCH CHAMPIONSHIP** is for Competitors participating in 'Hatchback' Cars available on general catalogued sale and available from stock through normal retail dealer outlets in the UK and as listed by the 750 Motor Club Limited. Applications for vehicles not included on this listing (in 6.1 of these regulations) are invited but

the 750 Motor Club reserves the right to refuse a particular make or model of vehicle.

Maximum engine capacities are:- Up to 1400cc multi-valve per cylinder and up to 1600cc two valve per cylinder plus the Citroën C2 VTS (not including the Loeb). These capacity limits are the original engine size and do not take into account any extra capacity gained by a rebore as permitted.

There are no restrictions on the trailering of cars to/from the circuit. All vehicles must comply with MOT requirements, be of sound construction and mechanical condition and be well maintained. There is no requirement for an MOT Certificate, Road Tax or Insurance. It is the intention of the 750 Motor Club Limited to equalise the performance of the cars by setting minimum weights (5.14.1) and by the addition of ballast (5.14.2). The 750 Motor Club reserves the right to amend any of the minimum weights specified in 6.1 at any stage of the season by giving 7 days notice. It is also the intention of the 750 Motor Club Limited to use other means if necessary to equalise the performance of cars by, for example, rev limiters or air intake restrictors. These restrictions may be imposed on any car and/or driver combination at any stage during the racing season. There is no appeal against the application or addition of ballast or other restrictions. All restrictors/rev limiters will remain the property of the 750 Motor Club Limited and must be returned in good condition to the Competitions Secretary within 2 weeks of the last round of each season.

**2) Examination of vehicles.** The organisers (in addition to any other powers they may have under these regulations) reserve the right before or after any race in the championship to designate any one or more of the competing cars for special eligibility scrutineering. Competitors must be prepared, with tools and spare parts as necessary, to enable inspection of components, or to have units sealed at the circuit for later inspection by an Eligibility Scrutineer at the Competitor's expense.

Upon such selection being made the competitor shall immediately place the car under the control of the organisers and be deemed to have permitted all such scrutineering, examination and testing as the organisers may reasonably require. The organisers have the right to:

- a) Examine the car at the circuit for such period as they may reasonably require and take fuel samples.
- b) Retain the car for detailed examination at premises chosen by the organisers. If the organisers elect to retain the car they shall make it available for collection by the competitor at least seven days prior to the qualification session for the next race in the championship unless the car is found to be in breach of these regulations.
- c) Seal the car and its components in such a manner as they may choose and require the competitor at their own expense to present the car at any other premises chosen by the organisers for detailed examination within a specified period and / or remove the car by transporter at no expense to the competitor to an appointed location. The competitor will be advised in writing of the time, date and location of the subsequent testing or eligibility examination. The overseen stripping of the engine or any required component will be undertaken by the competitor and / or mechanic / technician nominated by the competitor.

### 5.3: SAFETY REQUIREMENTS:

The following Articles of MSA Section K Safety Criteria Regulations will apply:- Drawing 3 or 4 (with a compulsory diagonal from the junction of the main roll hoop behind the driver's head down to the foot of the main roll hoop on the rear passenger side and a compulsory side entry bar on the driver's side); 1.5; Seat belts as per K2.1.2, 2.1.3 or 2.1.4. FIA homologated in accordance with Q19.14.2; K5 – K14. Extinguishers must comply with K 3.1.2 a). It is permitted to add two braces only, as per drawing 11 in section K of the MSA Year Book, from the front roll hoop through the front bulkhead/wheel arch to the front suspension anchorage points, no further forward than the centreline of the front wheels. The holes through which those tubes pass must be sealed to prevent the passage of fluid or flame from the engine bay; that sealing may be by welding or by intumescent putty or grp. Towing eyes must have a minimum internal diameter of 60mm; (note the tow eye may be of either a suitable rigid or flexible material bolted to the chassis).



# 750 Motor Club Stock Hatch Championship 2012

## Sporting & Technical Regulations

Final Version - Page 5 of 10 – Issued 06/01/12

### 5.4: GENERAL TECHNICAL REQUIREMENTS & EXCEPTIONS:

All cars must comply with the requirements of sections J and Q19 of the current MSA Yearbook. All vehicles must be of sound construction and mechanical condition and be well maintained. Water hoses, oil hoses and their associated clips are free. Fasteners (eg nuts, bolts) are free. **Gaskets are free. Rose Joints of any type are prohibited.** A TABLE OF TECHNICAL SPECIFICATIONS (6.3) HAS BEEN PREPARED FOR VARIOUS MAKES & MODELS OF CAR; THOSE LISTED MUST COMPLY WITH THOSE SPECIFICATIONS.

### 5.5: CHASSIS:

No chassis stiffening is permitted except that derived from the fitting of the roll cage using only the six mounting feet inside the car and two suspension anchorage points inside the engine bay; except for the welding of the forward facing tubes to the bulkhead/wheel arch at the point where they pass through the bulkhead/wheel arch no other attachment to the bodyshell is permitted even if provided by the cage manufacturer. Seam-welding of the shell is prohibited; fitting of a front or rear strut brace is prohibited.

### 5.6: BODYWORK:

(Refer to 5.1.)

#### 1. Modifications Permitted:

**1. General:** Mandatory fitment of laminated windscreen.  
**2. Interior:** Driver's seat may be replaced. Passenger seat, rear seats, floor coverings, roof lining, detachable boot covers, boot side panels, tailgate trim panel, radio/stereo units speakers and associated wiring, spare wheel and tools may be removed. Additional and/or replacement instruments are permitted; replacements must occupy the position of the original. Steering wheel may be changed (compulsory if an air bag is fitted as original equipment). Sunroofs must be replaced as per MSA regulation Q19.14.6. Electric window winding mechanisms may be replaced by the manufacturer's manual window winding mechanisms; all windows must remain operable and all weather strips/channels must be retained. It is permitted to remove the heater, heater motor and associated ducting and air-conditioning if fitted. An interior rear view mirror must be fitted to the left of the driver (or right if the car is left hand drive). Front door panels and rear passenger side panels may be replaced with aluminium sheeting - this must be executed to a high standard with no sharp edges and with smooth surface. The central locking mechanisms including locking motors and associated wiring must be removed; manual interior door lock mechanisms must be disabled. The standard door latching mechanism must be retained.  
**3. Exterior:** The standard wing mirror 'pods' must be retained but the choice of mirror within them is free. An additional mirror may be fitted to the passenger door. Plastic front wheel-arch inner liners must be removed. Bonnet and rear hatch locks/latches must be removed along with any auxiliary latch; the bonnet and rear hatch must be fitted with surface mounted securing pins. The original number of windscreen wiper arms/blades must remain and be fully functioning. Tailgate wiper mechanism and arm/blade must remain but need not be operable. Front and rear washer systems may be removed. No other alterations to standard. All weather strips/channels must be retained. Suitable flat mounting plates 510mm x 115mm high ( $\pm$  5mm on both dimensions) must be fitted to the normal number plate positions front & rear to carry championship decals as issued by the 750MC.

**4. Silhouette:** No alterations to standard.  
**5. Ground Clearance:** It is permitted to alter the ride height. Under no circumstance can any part of the bodywork, or of the suspended part of the car including the exhaust system, be below a horizontal plane passing 75mm above the ground, the car being in normal racing trim with the driver aboard. A gauge of 75mm may be used by Scrutineers before or after races or practice to check the ground clearance; the vehicle may be stationary or moving during any testing.

#### 2. Modifications Prohibited:

**1. General:** The exterior of the car must be standard for the model being raced. Any replacement body panels must be of original shape, material and thickness. No modifications may be made to or material removed from the bodywork or any of its panels including internal

stiffeners other than as repairs; exterior trim must be generally standard.

**2. Interior:** Door trims and panels, window winding mechanisms (except as detailed in 5.6.1.2 above) may not be removed. Any other modification in contravention of 5.6.1.2 is also prohibited. Detachable boot cover side supports, tailgate inner trim panel lower (not pillar trims), dash fascia/instrument cluster must remain as originally fitted with the exception of replacement of instruments as permitted in 5.6.1.2 and immediately localized trimming for the fitment of the rollcage.

**3. Exterior:** It is not permitted to increase the width of the wheel arch by the addition of material to, or the deformation of, the outside or inside of the wheel arch. Additional holes for cooling, brake ducting, air intake etc may not be made in the bodywork. Bonnet / engine cover must remain in the normal position and, when closed, must not have any non-standard gaps at any of their edges. If standard fitment auxiliary lights are removed, blanking plates must fill the resultant apertures. Fitment of tape etc to close body gaps (e.g. bonnet to wing) is prohibited. Recessed bonnet & rear hatch securing pins are prohibited.

**4. Silhouette:** Any in contravention of 5.6.1.4.

**5. Ground Clearance:** Any in contravention of 5.6.1.5.

### 5.7: ENGINE:

The engine must be the standard engine for the model being raced and must use the standard components, as listed below, used in the original build of new standard engines. The only non standard components that are permitted are those listed in **1 (Modifications Permitted)** below.

The only modifications permitted to engines are those listed in paragraph 1 (Modifications Permitted) below; if the following texts do not clearly specify that you can do it, you must work on the principle that you cannot. It is the competitor's responsibility to ensure that no prohibited modifications have been carried out, if they are using an engine not assembled by them.

**Checking will be by comparison to spare parts supplied by the manufacturer's official agent or by any other means necessary to ensure compliance.**

**All engines must have at least two bolts/nuts cross-drilled with a hole of minimum 1/16<sup>th</sup> diameter to accept scrutineer's locking wire, for the rocker cover, sump, timing cover, bellhousing and gearbox.**

**The engine must use the following standard components: -**

- Cylinder Block including the main bearing caps and bolts.
- Crankshaft
- Connecting rods including the caps and bolts
- Standard or standard pattern pistons [see 9.1 additional specific regulations]
- Standard Cylinder head [see 9.1 additional specific regulations]
- Inlet manifold
- Exhaust manifold
- Rocker cover
- Sump [subject to 5.7.4]
- Oil pump [subject to 5.7.4]
- Flywheel [see 9.1 additional specific regulations]
- Valve gear including rocker shaft supports

#### 1. Modifications Permitted:

##### General

It is permitted to reclaim engine blocks by fitting liners or by re-boring up to 0.5mm (**1.0mm Classic Stock Hatch**) oversize using standard-pattern pistons only. Replacement of valves, valve guides and valve seats with parts of standard pattern and material. 3 angle valve seats are permitted provided the 45° portion has a minimum width of 1.5mm. Cylinder heads with original 30° valve seats may be modified to 45° seats with a minimum seat width of 1.5mm. (For 2013 this red underlined permitted modification will be prohibited.)

With the exception of cars listed in 6.3 of these regulations, all cars must use the camshaft specified by the manufacturer of their vehicle as being the standard part for the make & model of car being raced.

##### Pistons.



# 750 Motor Club Stock Hatch Championship 2012

## Sporting & Technical Regulations

Final Version - Page 6 of 10 – Issued 06/01/12

The pistons may not be modified by the addition or removal of material except as follows:- Pistons may only be modified for the purposes of balancing; this may only be carried out by removal of material below the gudgeon pin centreline and only 3 pistons may be adjusted. It is not permitted to machine the piston crown by any means. The piston crown must display any marking placed there by the manufacturer. The annular face on the outside of the crown of the piston may not protrude above block face.

### Cylinder Heads.

Apart from the replacement of valves, valve guides and valve seats with parts of standard pattern and material the cylinder head may not be modified by the addition or removal of material by any means except for the skimming of the sealing face that mates to the cylinder head gasket. Inlet and exhaust ports may not be modified in any way and must remain as cast.

## 2. Modifications Prohibited:

**No components other than those specifically mentioned in section 1. Modifications Permitted (above) and 5.8 may be modified in any way - checking will be by comparison to spare parts supplied by the manufacturer's official agent or by any other means necessary to ensure compliance. The fact that some modifications are mentioned as prohibited does not imply that others are allowed.**

The camshaft must remain entirely unmodified; it is not permitted to regrind or reprofile or grind from blanks. The standard cambelt cover/s must be retained. Valve seats and seat angles may not be modified except as permitted in 5.7.1 above.

The Crankshaft and Camshaft drive sprockets must be standard and use the standard timing dowels or keys.

**3. Location:** Position and mounting method must be standard for the model being raced. No additional engine/transmission supports may be fitted.

**4. Oil/Water cooling:** With the exception of the Citroen Saxo VTR the water radiators must remain standard in design and position with no additional air ducting; Citroen Saxo may use radiator Part No: 1331TH. Oil coolers are permitted if standard for the model being raced, but must be fitted in the standard position; if none is fitted as standard an oil cooler may be fitted within the overall periphery of the engine bay; no additional air ducts are permitted. Internal baffles may be fitted to the standard sump; the sump oil pick-up pipe may be modified.

**5. Induction Systems:** With the exception of the Peugeot Rallye the complete standard induction system must be retained in its entirety; it is not permitted to add any covering, whether heat-reflective/heat-resistant or not, to the inside or outside of any part of the induction system. Air filter elements may be removed or replaced by non-standard filter elements inside the standard casing. Carburettor jets / fuel injectors may be changed; choke flaps on carburettors and butterfly damper weight on throttle bodies may be removed. No other modifications are permitted. The crankcase breather may vent direct to a catch tank and any holes in the air filter housing associated with the breather system may be blanked off. **The Ford XR2 may use the carburettor listed in 9.4.** If the vehicle is fitted with a 'fly by wire' (motorised) throttle this may be removed and replaced by a cable type actuation which may use a non standard throttle pedal.

**6. Exhaust systems:** The exhaust manifold may not be modified by the removal or addition of any material. See also Fig. 7 and 8 in Appendix 1 for details on the Citroen Saxo.

The exhaust systems must exit at the rear of the vehicle. Exhaust systems may not pass through the driver/passenger compartment. Standard exhaust manifold must be retained and may not be modified by the removal of material. The remainder of the exhaust system including silencer is free but no part of the manifold, piping or silencer may have any covering or lagging, whether heat resistant, heat reflective or not.

The Citroen C2 may be fitted with the Citroen Sport C2R2 exhaust system.

All vehicles except those running in Classic Stock Hatch must be fitted with a catalytic converter in the exhaust system. Close coupled (in manifold) catalysis may be removed and replaced with a catalytic converter fitted in the exhaust system.

**7. Ignition systems:** The ignition system is free but no additional sensors may be fitted. The ECU is free and re mapping of the ignition and fuelling is permitted. However no additional sensors can be added. For 1600cc 16 valve engines the ECU Fitted must be as follows: - Citroën C2 VTS Free. ECU functions and software that have and provide Traction Control or Launch Control must be disabled as these functions are prohibited.

**8. Fuel delivery systems:** It is permissible to replace only the fuel pump, fuel lines, and filter with non-standard items. Fuel pressure valves are free, for both fuel-injected and carburetted cars.

## 9: Additional Specific regulations

### 9.1 Citroen Saxo VTR.

- Cylinder block:** Any standard Saxo VTR cylinder block may be used.
- Cylinder head:** The only Cylinder heads permitted will be the Mk1 and Mk2 heads as shown in Appendix 1 figs 10, 11, & 13.
- Pistons:** Any of the Standard pistons shown in Appendix 1 figs 1, 2, 3, 5 & 6 may be used
- Flywheel:** Either flywheel shown in appendix 1 Fig 17 is permitted with a minimum weight 5.4kg.

### 9.2: Citroen C2VTS

- Cylinder block:** Any standard C2 VTS cylinder block may be used. It may be reclaimed by machining and fitting liners or by re-boring by up to 0.5mm oversize.
- Cylinder head:** The only Cylinder head permitted will be that as shown in Appendix 3 Fig 1. Valve seat may be 3 angle provided the 45° portion has a minimum width of 1.0mm.
- Ports:** The ports must remain entirely as cast and originally machined; it is not permitted to add or remove material from the valve throats.
- Pistons:** The only pistons permitted are as shown in the Appendix 3 fig 5.
- Camshaft:** The inlet camshaft must be Citroen cam marked TU5 JP48. The exhaust cam must be Citroen cam marked TU5 JP4S.
- Flywheel:** The flywheel shown in Appendix 3 Fig 3 is permitted with a minimum weight 5.75kg.

### 9.3: Peugeot 106XSi/Rallye

- Pistons:** For the XSi only the pistons shown in Appendix 1 figs 1, 2, 3. For the Rallye only the piston type as shown in Appendix 1 fig 5.
- Induction system:** It is permitted for the Peugeot 106 Rallye to fit the complete induction system (as detailed in 6.4 of these regulations) from the 106 XSi as an alternative to the standard induction system.

### 9.4: Ford XR2

- Carburettor:** Due to unavailability of original parts, the Fiesta XR2 may fit the DMTR carburettor which must retain the original size chokes of 25 & 26mm, with barrel sizes of 32 & 32mm.

## 5.8: SUSPENSIONS:

**(Refer to 5.1).** The original suspension configuration must be retained. Standard anti-roll bars must be retained and be properly connected. Standard chassis bump-stops must be fitted in the standard position.



# 750 Motor Club Stock Hatch Championship 2012

## Sporting & Technical Regulations

Final Version - Page 7 of 10 – Issued 06/01/12

**1. Permitted modifications:** It is permitted to alter the ride height within the constraints of 5.6.1. Coil-over dampers (ie Combined dampers and coil springs) may only be used if standard fitment. Uprated/lowered springs are permitted provided they are the same outside diameter as the standard coil. Uprated torsion bars may be fitted. Uprated dampers, including those on which the camber has been modified, are permitted provided they mount on the standard mounts and have no more than one adjuster. The front strut piston rod diameter may be increased from standard to a maximum of 28mm. A plastic/rubber dust exclusion gaiter may be fitted to the dampers but this must have a stiffness in bending of less than 50N/mm when rigidly supported at one end and subject to a radial and normal force at the free end. Adjustability of suspension geometry with the exception of camber is limited to that provided by the vehicle manufacturer for the standard suspension. The Peugeot 205 must have a spacer of 25mm under the bump stop to prevent chafing of the fuel tank filler pipe, if the standard fuel tank & filler are retained.

**2. Prohibited modifications:** Modifications to the suspension pick-up points are prohibited; this includes the 'slotting' of top suspension strut mounting points. Cockpit adjustable anti-roll bars are prohibited. Offset and/or adjustable suspension strut mounts are prohibited. Adjustable spring platforms and hub-carrier brackets are prohibited, even if the adjustability is disabled. Dampers with separate adjustment for rebound and bounce are prohibited, as are dampers with remote reservoirs. Non-standard suspension bushes are prohibited; rose joints, rod ends or similar are prohibited. Any modification which prevents a wheel from reaching its fully drooped position is prohibited. Front strut inserts may not be fitted inverted such that the body is fixed to the top strut mount. The piston rod must be fitted uppermost and connect to the top strut mount. The piston rod must not exceed 28mm diameter maximum. The piston rod and the spring must be the only components connecting the body of the suspension strut and/or the damper to the top mounting of the suspension strut. It is not permitted to use a ferrous/non ferrous sliding dust exclusion sleeve.  
For 1600cc 16 valve engines the wheel camber angles front and rear must be as specified in (6.3).

**3. Wheelbase/track:** The wheelbase and track must be standard for the model being raced, **or be as detailed in 6.3.**

### 5.9: TRANSMISSIONS:

(Refer to 5.1).

Gear selection, clutch and throttle operation must be purely mechanical and solely under direct control of the driver. The gear linkage and clutch system must be purely mechanical (hydraulic clutch systems are permitted). No electrical connections, switches or sensors may operate on any part of the clutch or gear controls or linkages.

**1. Permitted modifications:** Standard gearbox and final drive/axle for the model being raced must be retained or be as detailed in 6.3. Clutch cover and plate may be changed for uprated standard pattern items. Citroen C2 paddle shift may be replaced with Citroen manual gearchange.

**2. Prohibited modifications:** Four wheel drive is prohibited. Gearbox casing, bell housing and tail shaft (if applicable) must be standard for the model being raced. Final drive housing (if applicable) must be standard for the model being raced. Limited slip, locked, locking, torque biasing differentials or similar are prohibited even if fitted as standard.

**3. Transmissions & Drive ratios:** The use of any electronic traction control device is prohibited. Standard gearbox ratios and final drive ratios for the model being raced must be retained.

### 5.10: ELECTRICS

**1. Exterior Lighting:** Must be as per standard fitment and to EC requirements and be fully operational. Lights must be taped to MSA regulations.

**2. Rear Warning Light:** An LED rear fog light to EU regulation 7, an FIA homologated LED rear warning light, or an LED stop light to EU regulation 38 is mandatory and must be fitted within 10cms of the centreline of the rear window and be located between the top and

bottom edge of the glass. Non integral rear fog lights may be removed. Integral rear fog lights must be rendered inoperative.

**3. Batteries:** No restrictions on type subject to MSA regulations; location must be as standard. A battery and electric starter motor must be fitted and be capable of repetitive starts. No external (slave) batteries may be used.

**4. Generators:** A fully working standard alternator/generator and standard pulley must be fitted and electrically connected so that the standard battery charging function is providing a charge to the onboard battery.

### 5.11: BRAKES

**1. Permitted Modifications:** Non-standard linings. Deformation or removal of back plates. Additional ducting within the overall periphery of the bodywork. Fitting of alternative brake piping/hosing. ABS is permitted only if standard for the model being raced. Discs and drums may be replaced by standard-pattern 'non-genuine' parts. Brake biasing valve/system may be replaced with a proprietary pressure-limiting valve, which may be adjustable by the driver but must provide a minimum of 25% of braking effort to either axle as per MSA Regulation Q19.5. The braking system must remain fully operational in all aspects at all times. For 1600cc 16 Valve cars all ABS wheel sensors must be removed.

**2. Prohibited Modifications:** Discs / drums may not be cross-drilled or grooved. An hydraulically-operated handbrake is not permitted in that it does not comply with MOT requirements.

### 5.12: WHEELS / STEERING

**1. Permitted Options:** Wheels must be standard for the model being raced. Simple 'clean-up' machining/polishing and painting for refurbishment purposes only is permitted to the outer face of the wheel. No machining at all is permitted to the inner face of the wheel. The Citroen C2 may fit 185/55 x 14 tyres on Saxo VTR wheels. The Ford Sportka may fit 195/50 x 15 tyres on standard Fiesta Zetec S wheels. Citroen Saxo may replace the power steering rack with a non-power steering rack Part No: 4000W7 and remove the power steering pump.

**STEERING LOCK:** If fitted with a steering lock, this should be rendered inoperative, unless the vehicle is driven to the circuit on the highway. MSA regulation Q19.6.

**2. Prohibited Options.** None of the VO, VK or ES extensions in the vehicle's homologation papers is permitted.

**3. Construction & Materials:** Not applicable; standard wheels must be used.

**4. Dimensions:** See 5.12.1.

### 5.13: TYRES

**1. Specifications:** Tyres must be road-legal in every respect. The use of tyre heating/heat retention devices, tyre treatments and compounds is prohibited. No alteration to the tyre from the manufacturer's specification is permitted. Re-cutting, re-grooving or in any other way modifying the tread pattern is not permitted. All the manufacturer's data must be clearly visible. Buffing of sidewalls to remove data is prohibited.

**2. Nominated Manufacturers:** Yokohama AO48R in M compound only. If tyres of the standard width and/or profile are not available for the standard diameter rims, permission must be sought from the 750 Motor Club to fit a different profile tyre.

**Nominated supplier:** Demon Tweaks.

### 5.14: VEHICLE WEIGHT:

**1.** A minimum weight including driver will be set for all makes and models of eligible cars. All minimum weights are including driver and race overalls, helmet etc. Random checks will be carried out during the season and no car/driver combination shall be below this minimum weight. Ballast must be added by competitors in accordance with 5.14.2 and must be carried in the car as per 5.14.3.

**2.** Ballast must be added (or deleted) after each championship round, including 'double-headers'. 20 Kgs will be added for 1st place. 10 Kgs will be added for 2nd place. 5 Kgs will be added for 3rd place. Ballast will be limited to the cumulative total of the last five race finishes – a 'DNF' does not count as a race finish. Ballast applies to the



# 750 Motor Club Stock Hatch Championship 2012

## Sporting & Technical Regulations

Final Version - Page 8 of 10 – Issued 06/01/12

car and driver. A change of driver or car will have no effect on the amount to be carried. An initial minimum of 10 Kgs ballast accumulation is required before the first ballast is physically added to the car. If any vehicle is underweight at post-race scrutineering, penalties as per 4.1 of these regulations will be applied.

**3.** Ballast must only be mounted inside the car on the front or rear passenger floor area. It is the responsibility of the competitor to provide and fit their own ballast as per the drawing in the Appendix 6.2 and to mount it to the satisfaction of the scrutineers. (Care should be taken in the mounting, by use of suitable 'spreader plates' and appropriate size and quality of bolts with reference to MSA regulation J5.15.

### 5.15: FUEL TANK / FUEL

**1. Types:** Safety tanks are permitted. If the standard fuel tank is used, no modifications to it are permitted. A non-return valve must be incorporated in the vent system.

**2. Locations:** Fuel tanks may not be mounted within the driver/passenger area, otherwise position free subject to MSA regulation Q19.

**3. Fuel:** Only petrol as defined in Section B Nomenclature & Definitions, **Pump Fuel a)** section of the MSA Yearbook for the current year and complying with BS4040, BSEN228 or BS7800 may be used; fuel which exceeds the stated RON (max) levels in Appendix 1 of Section B Nomenclature & Definitions is prohibited even if it is sold/promoted as being legal for UK Competition and/or obtainable from 'roadside' pumps. The use of additives by competitors which boost the octane rating (RON) in any petrol is prohibited. At the end of practice and the race at least 3 litres of petrol from the tank of the competing car must be available to the scrutineers for analysis. Compliance with minimum weight for the car will be taken before the petrol is removed.

### 5.16: SILENCING:

All vehicles must comply with the relevant maximum noise limits set out in MSA Blue Book regulation J. Chart 5.18.

### 5.17: NUMBERS & CHAMPIONSHIP DECALS

**1. Positions:** Race numbers must be displayed on each side of the vehicle alongside the cockpit/driver and as far forward on the front of the vehicle as possible. 750 Motor Club decals must be affixed prominently near all number backgrounds. Championship Sponsor's decals (where applicable) must be affixed in or near the positions detailed on any diagram supplied with those decals. Cars will also be required to carry 750MC championship decals on front & rear number plates in the normal number plate position. 750 Motor Club and Championship Sponsor's decals must take preference to any other decals. Failure to comply will render the vehicle and driver ineligible to race.

**2. Suppliers:** Sponsors and Club decals will be available at the first championship race in which the vehicle is entered.

## 6. APPENDICES:

**6.1. ELIGIBILITY GUIDE:** This list has been prepared as a guide to the most popular cars that are eligible for the above Championship, but is not totally definitive. Most manufacturers include a variety of body types, engine sizes and types, some of which will not be eligible. The deciding factors are that the car must be listed as a hatchback in Parkers Used Car Guide and the engine must not be over 1400cc if it has more than 2 valves per cylinder or over 1600cc if it has only 2 valves per cylinder; forced induction models are not permitted. Any exceptions to that are specifically listed below. The car, as raced, must have been available on general catalogued sale and available from stock through normal retail dealer outlets in the UK. Models that have been raced are listed with the minimum weight including driver; weights for other cars are available from the Championship co-ordinator. Applications for inclusion of cars not listed will be processed within 21 days; the 750 Motor Club reserves the right to refuse a particular make or model of vehicle.

*Those cars underlined and in italics are eligible for Classic Stock Hatch. (see section 1.6)*

### AUSTIN ROVER:

*Metro 1.4 GTi - 840Kgs* (note Weight increased to permit the use of Wossner pistons see Appendix 6.3).

*Maestro 1.6 R or S - 1057Kgs.*

### CITROEN: *Visa 1.6 - 886Kgs; AX GTi - 801Kgs; AX GT - 733Kgs.*

Saxo VTR to Stock Hatch specification - 910Kgs.

Saxo VTR complying with all SAXMAX regulations, but running on M Compound AO48R tyres **with free ECU as per 5.7.7 - 940kgs including driver.**

C2 VTS (not including the Loeb) – **1020kg.**

### FIAT: *Uno - 760Kgs.*

### FORD:

*XR2i - 875Kgs; XR2 - 831Kgs; XR3i - 890Kgs; XR3 - 873Kgs.*

Fiesta 1.4 Si - 840 Kgs.

Sportka – 910 Kgs.

*Escort RS1600i (1981-84) – 893kgs.*

MG ZR105. – 940Kgs. Only eligible on 16" wheels with 195/50 x 16 tyres.

### PEUGEOT:

*309XSi - 900Kgs; 205 GTi 1.6 - 890Kgs;*

106XSi 1.6 - 910Kgs.

106 Rallye is eligible only in 1600cc version and has a 920kgs minimum weight.

*106XSi 1.4 (8 valve) – 885kgs.*

### RENAULT:

Clio 1.4 16v – 920Kgs.

### ROVER:

*214 – 960Kgs.*

1999 214iS – 945 kgs, eligible only on 15" wheels with 55 profile tyres.

### SUZUKI: *Swift GTi - 770Kgs.*

VAUXHALL: *Nova 1.6 - 836Kgs.* Corsa – 875Kgs.

VW: *Golf GTi 1.6 - 845Kgs.* Lupo – 910Kgs

### 6.3 Wheelbase:

#### Citroen

Saxo 2390 mm ± 5mm

106 2390 mm ± 5mm

Rallye 2390 mm ± 5mm

#### Peugeot

205 2420 mm ± 5mm

#### Ford

XR2 2288 mm ± 5mm

XR2i 2446 mm ± 5mm



# 750 Motor Club Stock Hatch Championship 2012

## Sporting & Technical Regulations

Final Version - Page 9 of 10 – Issued 06/01/12

6.3. TECHNICAL SPECIFICATIONS: Where specifications are stated within this table they are mandatory for that make and model of car.

The omission of data in any part of this table is because at the time of preparation validated data was not available; the lack of data does not indicate that anything other than the standard part may be fitted.

Make	Model	Final Drive Ratio	Gearbox Type	Gearbox Ratios					Anti Rollbar dia		Engine Code(Type)	Cylinder Head Code	Minimum Cylinder Head thickness	Head Gasket thickness	Caster Angle Front	Camber angle +/- 0.5°		Camshaft		Minimum flywheel weight
				1 <sup>st</sup>	2 <sup>nd</sup>	3 <sup>rd</sup>	4 <sup>th</sup>	5 <sup>th</sup>	Front	Rear						Front	Rear	Inlet	Exhaust	
Citroen	C2V TS	14/60	MA5S	12/41	20/39	30/41	37/39	41/35	21mm	26mm Hollow	TU5JP4S (NFS)	TU5JP4	135.0mm	0.62mm	5.0°		-1.5°	TU5 JP48	TU5 JP4S	5.75Kg

Citroen C2VTR Piston height Minimum Over all height 49.8mm. Gudgeon pin to top of piston 33.2mm

Make	Model	Camshaft Number	Final Drive Ratio	Gearbox Ratios					Anti Rollbar dia		Minimum flywheel weight	
				1 <sup>st</sup>	2 <sup>nd</sup>	3 <sup>rd</sup>	4 <sup>th</sup>	5 <sup>th</sup>	Front	Rear		
Peugeot	106 XSi (1600)	Kent Cams: KC750J*	16/65	12/41	20/39	28/38	37/39	41/35	20mm	19mm	5.4Kg	
	106 Rallye								22mm	24mm	5.44kg	
	205 GTi	Kent Cams: KC750205*	4.063:1	3.251	1.850	1.360	1.069	0.865	17mm	19.5mm	5.37kg	
Citroen	Saxo VTR	Roller rocker heads – Kent Cams: KC750R* Non roller rocker heads: - Big journal cams: Kent Cams: KC750J* or for Small journal cams: KC750N*	Citroen Saxo VTR	17/61	12/41	20/39	28/38 or 30/41	37/39	41/35	22mm	22mm	5.4Kg
Ford	XR2	FoMoCo 1614767 / Kent Cams KC7501614767 or FoMoCo 6186554 / Kent Cams KC7506186554		17/65 or 17/69	13/41	23/44	29/37	41/39	45/34	None	14mm	6.5kg
	XR3											
	XR2i	XR2i & XR3i with <u>electronic</u> injection – FoMoCo 6179242 or <b>Piper Standard Profile Pt No:MC6250</b>		17/69						16mm	20mm	6.5kg
	XR3i	XR3i with <u>mechanical</u> injection – any XR2/XR3 cams above.		17/73								
	Sportka	KC750FKA*										
Suzuki	Swift		4.105	12/41	19/36	24/33	33/34	31/27	22mm	15mm	5.044kg	
Rover	Metro GTi	Kent Cams: KC750RK14*							Wossner pistons Pt. No.9221DA* Or Std			
MG	ZR105	Kent Cams: KC750RK14*							Wossner pistons Pt. No.9221DA* Or Std			
Vauxhall	Nova	Kent Cams: KC750SE16*										

\* The Kent Cams detailed above for the Peugeot, Citroen, Ford Sportka, Vauxhall, MG and Rover cars are the only camshafts permitted and will be ID marked by Kent Cams. Contact Details: Kent Cams - Andy Burns Tel: 01303 248666

Rover Metro GTi Wossner pistons Pt. No.9221DA with piston crown machined to the same form as the Original Equipment but with only 4 valve pockets.

### 6.4: Induction System/Filtration Drawings

#### Peugeot 106 XSi induction

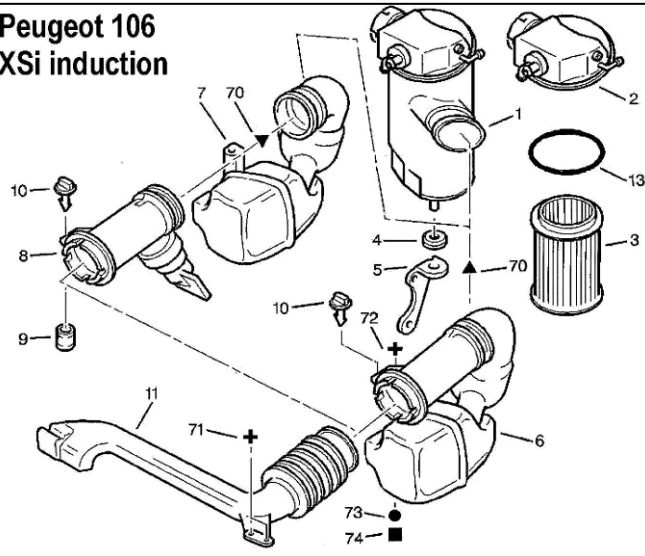

#### Peugeot 106 Rallye induction

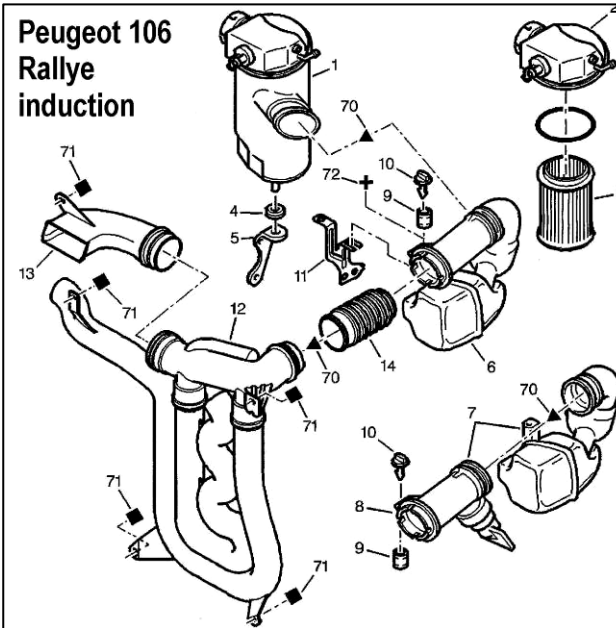

#### Citroen Saxo VTR induction

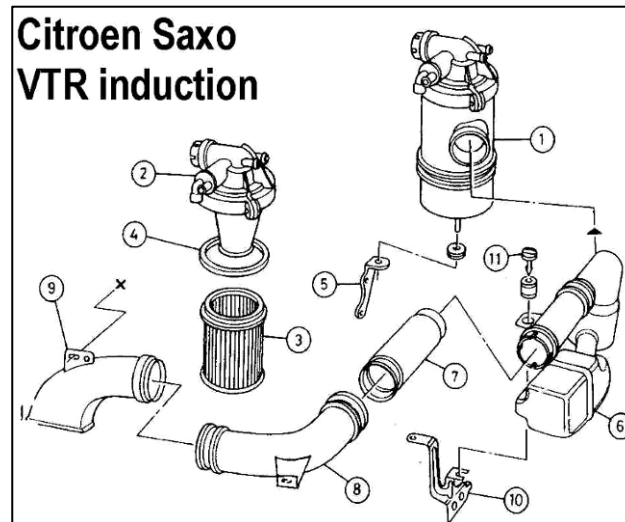

#### 6.2: 5 kg BALLAST PLATE DRAWING

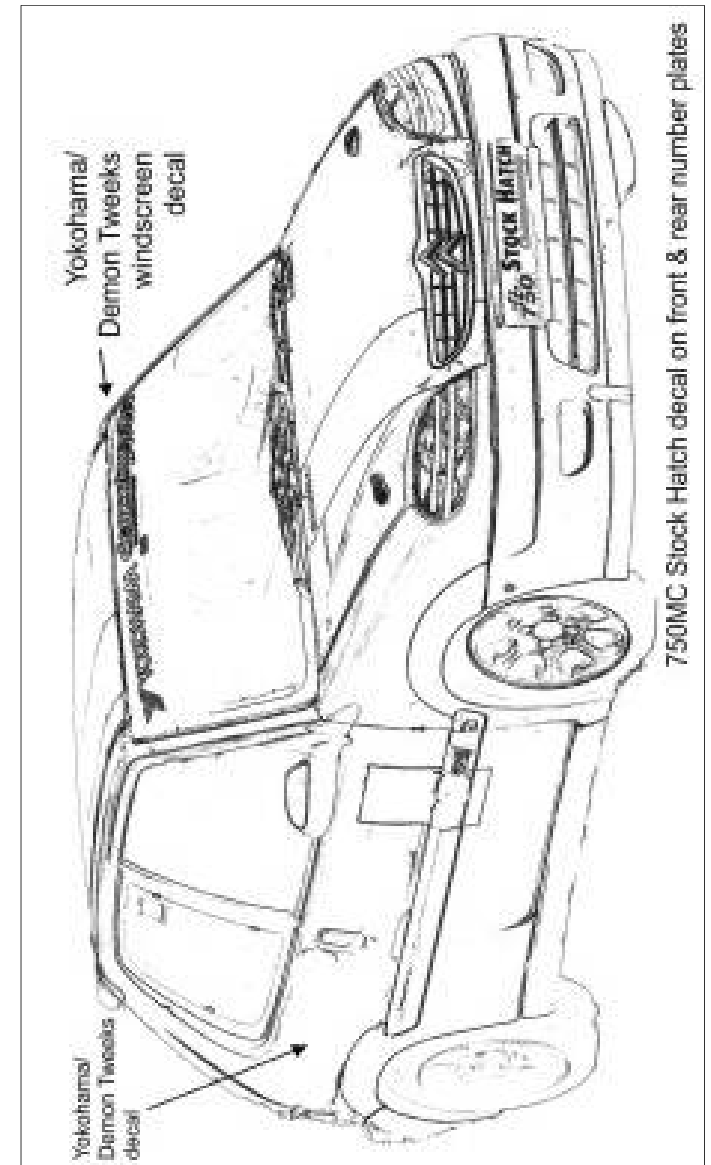
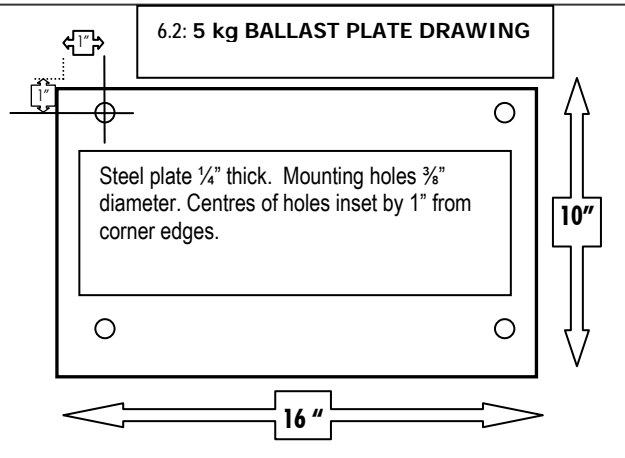

# Appendix 1 Citroën Saxo VTR



Fig 1: Permitted Mahle piston  
No:0400400. Weight 320g  
without gudgeon pin



Fig 3: Permitted piston  
short skirt raised crown 0.75mm  
stamped 062 12



Fig 2: Permitted piston  
long skirt raised crown 0.75mm  
stamped 390 15



Fig 5: Permitted dished piston



Fig 6: Permitted dished piston



Fig 4:  
Prohibited  
domed piston.  
Remains  
prohibited even if  
machined flat.



# Appendix 1 Citroën Saxo VTR

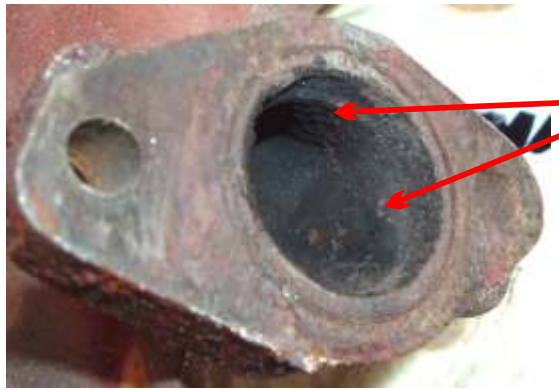

These details must remain

Fig 7: Mk1 and Mk2 exhaust manifold

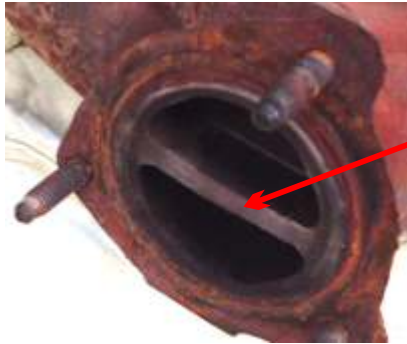

Fig 8: Permitted Mk1 & Mk2 exhaust manifold

This detail must remain



Fig 9:  
Prohibited Mk3 manifold



Fig 11: Permitted head Mk1



Fig 13: Permitted head Mk2



Fig 10: Permitted head Mk1



Fig 14: Prohibited head Mk3



Fig 15: Prohibited head Mk3

# Appendix 1 Citroën Saxo VTR

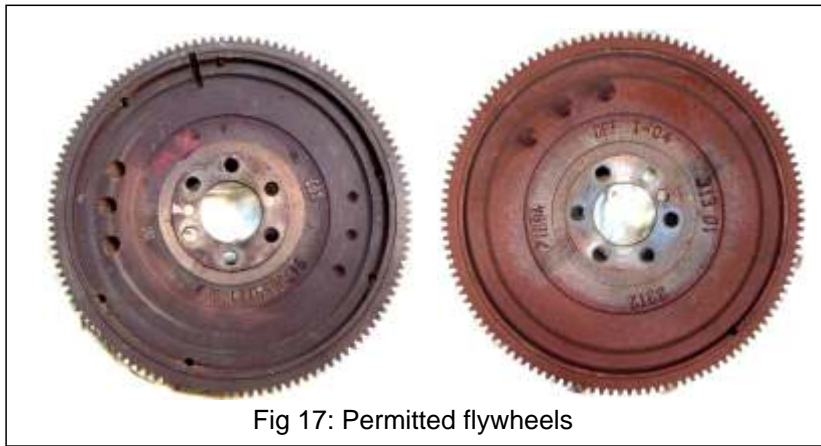

Fig 17: Permitted flywheels

## Appendix 3 Citroën C2

Fig 1: Cylinder head 9656799580



Fig 2: Inlet ports showing casting marks



Fig 3:  
Flywheel  
friction side  
and back



Fig 4:  
Bottom end of engine  
showing crank and rods  
with detail of crank and  
one rod



Fig 5:  
Permitted piston

