



1: SPORTING REGULATIONS

1.1: TITLE & JURISDICTION:

The **GOLF GTI CHAMPIONSHIP** is organised and administered by the 750 Motor Club Ltd in accordance with the General Regulations of the Royal Automobile Club Motor Sports Association (incorporating the provisions of the International Sporting Code of the FIA) and these Championship Regulations.

- 1. MSA Championship Permit No: CHR2008/116.**
- 2. MSA Championship Grade: D.**
- 3. Race Status: Clubman/National B.**

1.2: OFFICIALS:

1. Co-Ordinator: R.G.Knight, Rose Farm, Upper Street, Oakley, Diss, Norfolk. IP21 4AX.

(☎ 01379 741641; ✉ 750MC@btconnect.com).

2. Eligibility Scrutineers:

R.Blackmore

Eligibility may also be checked by any of the following:

D.F.D.Smith; C.Baker; A. Johnson; M.Lambkin-Smith.

3. Championship Stewards:

K.Messer. D.Wells. R.Armstrong.

1.3: COMPETITOR ELIGIBILITY:

- Entrants must be fully paid up valid membership card holding members of the 750 Motor Club Ltd and possess a valid current year's MSA Entrants Licences.
- Drivers must be fully paid up valid membership card holding members of the 750 Motor Club Ltd, be registered for the Championship and hold a valid MSA National B (or higher grade) Race Licence or be a professional driver in possession of a valid Licence (featuring an E.U flag) & medical issued by the ASN of a member country of the European Union [C(a) 52].
- All necessary documentation must be presented for checking at all rounds when signing-on.

1.4: REGISTRATION:

- All drivers must register for the championship by returning the Registration Form with the Registration Fee to the Coordinator prior to the Final Closing date for the first round being entered.
- The Registration Fee is £125.00 (or £75 for those registered for the 2007 series) payable to the 750 Motor Club upon registration.
- Registrations will be accepted from 1st January 2008 until the closing date for the last round of the championship.
- Registration numbers will be the permanent Competition number for the Championship.
- Change of Registered Vehicle: Should any driver wish to change his vehicle from the one originally registered for the current season, application must be made to the Championship Co-ordinator (1.2.1) together with a completed Registration Form and Registration Fee.

1.5: CHAMPIONSHIP ROUNDS:

The **Golf GTI Championship** will be contested over the following rounds:

Date	Circuit	Round/s
Mar 16	Snetterton	1
Apr 19	Brands	1
May 11	Cadwell	1
Jun 8	Anglesey	2
Jul 20	Donington	1
Aug 3	Mallory	1
Aug 23	Silverstone	1
Sep 6	Oulton	1
Sep 28	Snetterton	1

1.6: SCORING:

All drivers will compete for the Golf GTI Championship, with Awards as per 1.7 below.

- Points will be awarded in each class to Competitors listed in the Final Results as follows:- 15; 12; 10; 9; 8; 7; 6; 5; 4; 3; all other finishers
- All non-finishers 1. Fastest race lap in each class
- If there are less than 5 starters in a class, the points scoring will be:-

12; 10; 9; 8. If there is only one starter in a class, there will be no point awarded for fastest lap.

2. The totals from all qualifying rounds (excluding any races which are abandoned and which are not replaced) less 1 will determine the final championship points positions.

3. Ties shall be resolved by, when more than one competitor have equal totals, adding their next highest or subsequent highest scores until a conclusive result is found. If that fails to find a winner, the highest number of best results shall be taken into account.

1.7: AWARDS:

1. All awards are to be provided by the Organising Club unless agreed otherwise.

2. Per Round: Awards of 1st, 2nd and 3rd in class will be given, subject to the number of starters as follows:-

2 to 4 starters - 1st in Class only

5 to 7 starters - 1st & 2nd in class only

8 or more starters - 1st, 2nd & 3rd in class

3. Championship: Trophies to:-

1st, 2nd & 3rd overall.

1st, 2nd & 3rd in class.

Best prepared car.

4. Bonuses:

Per Round: not applicable.

Championship: Any monies which are available from sponsorship after payment of expenses and other deductions will be distributed to competitors finishing in the top 3 places in both classes.

5. Presentations: Garlands and Trophies are to be provided for presentation at the end of each race. Prize money and Bonuses shall be posted to the Entrants within one month of the results being declared final after each season.

6. Entertainment Tax Liability: Not applicable.

7. Title to all Trophies: In the event of any Provisional Results or Championship Tables being revised after any provisional presentations and such revisions affecting the distribution of any awards the Competitors concerned must return such awards to the 750 Motor Club Competitions Secretary in good condition within 7 days.

2: SPORTING REGULATIONS - JUDICIAL PROCEDURES

Rounds & Championship: In accordance with Section [C(d)] of the current year's MSA Yearbook and 4.2.2. of these regulations.

3: SPORTING REGULATIONS – CHAMPIONSHIP RACE MEETINGS & RACE PROCEDURES

3.1: ENTRIES:

1. Competitors are responsible for sending in correct and complete entries with the correct entry fees prior to the close of entry dates as per the entry forms.

2. Incorrect or incomplete entries (including driver to be nominated entries) are to be held in abeyance until they are complete and correct and the date of receipt for acceptance of entry purposes shall be the date on which the Secretary of the Meeting receives the missing or corrected information or fee.

3. Any withdrawal of entry or driver/car changes made after acceptance of any entry must be notified to the Secretary of the Meeting in writing. If driver/vehicle changes are made after the publication of Entry Lists with Final Instructions, the Competitor concerned will be accepted in accordance with A60 (I).

4. The entry fee for each round shall be as per the Supplementary Regulations.

5. In the event of any rounds being oversubscribed the Organising Club may, in liaison with the Championship Coordinator, at their discretion run Qualification races. For Qualification Race procedures see 3.13 of these regulations.

6. Reserves are to be nominated on the Final List of Entries published with the Final Instructions or Amendment Sheet Bulletins. Reserves will practice and replace non-qualified (including drivers practising out-of-session or qualifying by virtue of having raced at the circuit within the previous 12 months), withdrawn or retired entries in Reserve Number order irrespective of class. If reserves are given Grid Places prior to issue of the first Grid Sheets for any round, the times set in practice shall determine their grid positions.



If Reserves are given places after publication of the grid sheet and prior to cars being collected in the Official "Assembly Area" they will be placed at the rear of the grid and be started without any time delay. Otherwise they will be held in the Pitlane and be released to start the race after the last car to start the Green Flag Lap or last car to take the start has passed the startline or pitlane exit whichever is the later. Such approval to start MUST be obtained from the Clerk of Course.

7. Acceptance of Entries: Up to Closing Day, Race meeting organisers may accept up to the maximum number of starters permitted on the Track Licence for the circuit ("the maximum"). If entries received by closing day exceed the maximum, selection will be made in order of receipt. Those in excess of the maximum and up to 20% more will be treated as 'reserves'. If the maximum has not been reached by closing day, entries received after that date will be accepted strictly in order of receipt until the maximum is reached.

3.2: BRIEFINGS:

Organisers must notify competitors of the times and locations for all briefings in the Final Instructions or Official Race Day Bulletins for the meetings. Competitors must attend all briefings.

3.3: PRACTICE:

Practice sessions will be as per MSA Regulations G15. Should any practice session be disrupted, the Clerk of the Course shall not be obliged to resume the session or re-run sessions to achieve the championship criteria and the decision of the Clerk of the Course shall be final.

3.4: QUALIFICATION:

Each driver should complete a minimum of 3 laps practice in the car to be raced and in the correct session in order to qualify for selection and order of precedence as set out in MSA regulations G15. Drivers practising out-of-session or qualifying by virtue of having raced at the circuit within the previous 12 months will be placed at the back of the grid. The Clerk of the Course and/or Stewards of the Meeting shall have the right to exclude any driver whose practice times or driving are considered to be unsatisfactory - as per MSA Regulation G15.

3.5: RACES:

The standard minimum scheduled race distance shall be 13 minutes plus 1 lap whenever practicable but should any race distance be reduced at the discretion of the Clerk of the Course or Stewards of the Meeting, it shall still count as a full points-scoring round.

3.6: STARTS:

Unless modified by the Organising Club's Standing Regulations, the following regulations shall apply:-

1. There will be a minimum elapsed period of 3 minutes from cars being released from the Assembly Area to the start of the race or, if applicable, the green flag lap.

2. Start Procedure: In normal circumstances there will be no green flag lap. A 'two minute' board will be shown on the startline; engines should be started at this stage and the grid cleared of any pit crew. A 'one minute' board will be shown, followed by a '30 second' board; a '5 second' board will be displayed; approximately 5 seconds after this board is withdrawn the red lights will be switched on; after between 2 seconds and 7 seconds they will be switched off to start the race. In the event of the failure of these lights a National Flag will be used to start the race.

In circumstances where a green flag is used, it will be waved from the startline to commence the green flag lap. The pole position driver should set a reasonable pace during this lap and slow down on approaching the startline to allow the grid to close up. Drivers should resume their correct grid positions with the minimum of delay. Any drivers unable to start the green flag lap or start the race are required to indicate their situation as per MSA regulation G53. Drivers may make up any lost grid position during this green flag lap, BUT any drivers unable to maintain grid position to the extent that ALL other cars are ahead of them, may complete the green flag lap but MUST remain at the rear of the last row of the grid but ahead of any cars to be started with a time delay.

A '5 second' board will be displayed when the grid is stationary. Approximately 5 seconds after this board is withdrawn the red lights will be switched on; after between 2 seconds and 7 seconds they will be switched off to start the race. In the event of the failure of these lights a National Flag will be used to start the race.

3. Any car removed from the grid or driven into the pits after leaving the Assembly Area shall be held in the pitlane and may start the race after the last car to take the start from the grid has passed the startline or pit exit lane whichever is the later.

4. Excessive weaving to warm-up tyres - using more than 50% of the track width - and falling back in order to accelerate and practice starts, is prohibited.

3.7: RACE STOPS:

1. Case A – less than 2 laps completed by the race leader. The race will be declared null and void. The race will restart from the original grid positions. Competitors unable to take the restart may be replaced by reserves who will start from the back of the grid in reserve order. Gaps on the grid should not be closed up. The length of the restarted race will be determined by the Clerk of Course.

2. Case B – more than 2 laps completed by the race leader, but less than 50% of its duration. The (two part) race will restart from a grid set out by the finishing order of part one. The result of the race will be the finishing order at the end of part two. Non-runners at the time of the showing of the red flag may, solely with the permission of the Clerk of Course, be permitted to take the restart from the back of the grid in reverse order of their retirement. The Clerk of Course may order that the duration of the second part shall be of a shorter distance than originally scheduled or that it may be abandoned altogether.

3. If the leader has completed more than half of the race distance or duration it shall not be re-started (unless the Clerk of Course so decides), the results will be declared in accordance with MSA Regulation G23 and the race shall still count as a full points-scoring round.

3.8: RE-SCRUTINY:

All vehicles reported involved in contact incidents during races or practice must be re-presented to the Scrutineers before continuing in the races or practice.

3.9: PITS AND PITLANE SAFETY:

1. Pits: Entrants must ensure that the MSA, Circuit Management and Organising Club Safety Regulations are complied with at all times.

2. Pitlane: The outer lane or lanes are to be kept unobstructed to allow safe passage of cars at all times. The onus shall be on all drivers to take all due care and drive at minimum speeds in pit lanes.

3. Refuelling may only be carried out in accordance with the MSA Regulation G67-70, Circuit Management regulations and the SRs or Final Instructions issued for each Circuit/Meeting.

3.10: RACE FINISHES:

After taking the chequered flag drivers are required to: - Progressively and safely slow down, remain behind any competitors ahead of them, return to the pitlane entrance as instructed, comply with any directions given by Marshals or Officials and to keep their helmets on and harnesses done up while on the circuit or in the pitlane.

3.11: RESULTS:

All Practice timesheets, grid sheets and Race Results are to be deemed PROVISIONAL until all vehicles are released by Scrutineers after post-practice/race scrutineering and/or after completion of any judicial or technical procedures.

3.12: TIMING MODULES:

The 750 Motor Club utilise AMB transponder-based timing and competitors **must** have a compatible transponder fitted and advise the race organisers of its number prior to the event. The transponder is a TRANX 260 Direct Powered and is available from HS Sports Ltd – 01260 275708.



3.13: QUALIFICATION RACES:

If on closing date the number of entries received is appreciably more than the maximum number of starters permitted, the race meeting organisers will endeavour if feasible within the timetable, to run practice sessions and races to accommodate all entries, but are not obliged to do so. Procedures will be as published in the Final Instructions for the events concerned.

4: CHAMPIONSHIP RACE PENALTIES:

4.1: INFRINGEMENT OF TECHNICAL REGULATIONS:

1. Arising from post-practice scrutineering or judicial action: Should a vehicle be found ineligible, the Clerk of Course may impose any or all of the penalties set out in MSA Regulation [C(d) 36].
2. Arising from post-race scrutineering or judicial action: Should a vehicle be found ineligible, the Clerk of Course may impose any or all of the penalties set out in MSA Regulation [C(d) 39].
3. Additional specific Championship penalties: See 4.2.

4.2: INFRINGEMENT OF NON-TECHNICAL MSA REGULATIONS and the Sporting Regulations issued for the Championship:

1. The Clerk of Course may impose any or all of the penalties set out in MSA Regulation [C(d) 39].
2. In order to maintain standards of conduct, the Championship Organisers will monitor all Officials/Observers reports of adverse behaviour at race meetings. If any individual is included on two such reports during one racing season the Championship Organisers will request the Clerk of Course at future race meetings to consider specific observation of that driver's conduct.
3. The Clerk of Course may impose a 'Stop-Go' or 'Drive through' penalty during a race, in accordance with MSA Regulation G65.
4. Any Competitor who is penalised under the Championship Sporting Regulations at any stage of a Championship event and receives an allocation of penalty points on their race licence in accordance with MSA regulations, will receive a grid slot penalty at the next round in which they compete following the allocation of penalty points, equal to the number of penalty points which were allocated. Double headers will be considered as two separate rounds; however if the decision to allocate penalty points is delayed such that further round/s of the Championship have taken place since the offence, the grid slot penalty will be implemented at the next round in which they compete after the allocation of the penalty points.
The penalty will mean that a Competitor will be moved back grid slot places from their grid position (e.g. if a Competitor with a three grid slot penalty had a qualifying time that was good enough for pole position then the Competitor will start fourth on the grid). If for any reason the imposition of this grid penalty is impractical (such as the competitor's qualifying time, starting from the pitlane etc) or the offence occurs at the final meeting of the season, a time penalty of no less than 5 seconds and no more than 10 seconds will be added to the elapsed race time of the competitor.

5: TECHNICAL REGULATIONS

5.1: INTRODUCTION:

The following Technical Regulations are set out in accordance with the MSA specified format and it should be clearly understood that if the following texts do not clearly specify that you can do it, you should work on the principle that you cannot.

Competitors will be personally and solely responsible for ensuring that their cars comply with these regulations for each event at which they are entered. Queries concerning eligibility should be referred in writing to the Championship co-ordinator or Eligibility Scrutineer at least seven days prior to an event entered, to permit a ruling in advance of any meeting at which it is intended to compete.

c) STANDARD: The word '*standard*' used within these technical regulations as a description of components is to be interpreted as: - 'The specified component from the manufacturers parts list for the model / engine shown on the entry form or registration form. No modifications permitted beyond the repair or adjustment processes specifically specified by the manufacturers' workshop manual or

microfiche or electronic parts system, subject to any consolidation of parts records which incorrectly implies that such parts were used for period manufacture.' Checking will be by comparison to spare parts supplied by the manufacturer's official agent or by any other means necessary to ensure compliance. Where specifications for parts (e.g final drive, gear ratios etc) are stated within Table 6.5 of these regulations, they are mandatory for that make and model of car.

d) STANDARD PATTERN: The words '*standard pattern*' used within these technical regulations as a description of components is to be interpreted as: - 'The replacement part has the same form, shape and features as the *standard* part and is constructed using the same materials and manufacturing process'. (e.g. Cast pistons may not be replaced by forged pistons or 'machined-from-billet' pistons).

e) Homologation papers, including VO, VK or ES extensions, will not be accepted as proof of specification of any components.

5.2: GENERAL DESCRIPTION: (Refer to 5.1)

1. The Championship is for Competitors participating in naturally aspirated, right hand drive, front wheel drive Volkswagen Golf GTI vehicles, sold in the UK between April 1984 and March 1992, known as the 'Mark 2' variant. For avoidance of doubt, '*standard specification*' will always be made with reference to 1.8 litre Golf GTI vehicles sold through authorised United Kingdom Volkswagen dealers in that time period. UK-supplied catalyst-equipped models are not eligible. Overseas models, special order or forced induction versions are not deemed to constitute a specification reference source for the purposes of these regulations.

Bodyshells originating from the Golf GTI G60, as denoted by a larger floorpan tunnel, whether converted to right hand drive, are not eligible for the Championship. Motorsport-type bodyshells (as often but not exclusively denoted via blank chassis plates, lack of underseal, lack of wax injection, lack of production bracketry etc) are prohibited. Acid dipping, shot blasting or media blasting of bodyshells is prohibited.

2. Classes:

Class 1 – All 8 valve variants.

Class 2 – All 16 valve variants.

It is the intention of the 750 Motor Club Limited to equalise the performance of the cars by setting minimum weights (5.14.1). The 750 Motor Club reserves the right to amend any of the minimum weights specified in 5.14.1 at any stage of the season by giving 7 days notice. There is no appeal against the application or addition of ballast or other restrictions.

3. Examination of Vehicles:

The organisers (in addition to any other powers they may have under these regulations) reserve the right before or after any race in the championship to designate any one or more of the competing cars for special eligibility scrutineering.

Competitors must be prepared, with tools and spare parts as necessary, to enable inspection of components, or to have units sealed at the circuit for later inspection by an Eligibility Scrutineer at the Competitor's expense.

Upon such selection being made the competitor shall immediately place the car under the control of the organisers and be deemed to have permitted all such scrutineering, examination and testing as the organisers may responsibly require to undertake. The organisers have the right to:

a) Examine the car at the circuit for such period as they may reasonably require and take fuel samples.

b) Retain the car for detailed examination at premises chosen by the organisers. If the organisers elect to retain the car they shall make it available for collection by the competitor at least seven days prior to the qualification session for the next race in the championship unless the car is found to be in breach of these regulations.

c) Seal the car and its components in such a manner as they may choose and require the competitor at their own expense to present the car at any other premises chosen by the organisers for detailed

examination within a specified period and / or remove the car by transporter at no expense to the competitor to an appointed location. The competitor will be advised in writing of the time, date and location of the subsequent testing or eligibility examination.

The overseen stripping of the engine or any required component will be undertaken by the competitor and / or mechanic / technician nominated by the competitor.

5.3: SAFETY REQUIREMENTS: (Refer to 5.1)

The following Articles of MSA Safety Criteria Regulations will apply:- [C(c) drawing 5 or 6 (preferably with the upper mounting of the diagonal to be on the driver's side of the cage) and compulsory horizontal side entry bars as per [C(c) 20]]; 23; 45 four point or six point; 77-99; 102-116; extinguishers must comply with Table 56 (b); seat belts must be FIA homologated in accordance with G125.

5.4: GENERAL TECHNICAL REQUIREMENTS & EXCEPTIONS: (Refer to 5.1)

All cars must comply with the requirements of sections [C(b)] and G96-136 of the current MSA Yearbook. All vehicles must comply with MOT requirements (with the exception of emissions), be of sound construction and mechanical condition and be well maintained. A valid MOT Certificate must be presented at driver signing-on and be available for inspection on request by scrutineers. There is no requirement for Road Tax or Insurance. Table 6.5 lists Technical Specifications applicable to the models of car permitted to participate; those listed must comply with those specifications.

The presentation of the car is fundamental to the image of the Championship. Thus cars entered must be of a *standard specification* appearance and exhibit all items of external trim associated with a Mk2 Golf GTI.

In case of serious accident, an alternative age or model body shell may be used provided:

- No weight or other benefit is derived;
- The finished car's appearance corresponds with that of a Mk2 Golf GTI. The age of the replacement bodyshell dictates the type of external trim to be fitted (bumper type, door type, etc) in order that the car does not present the image of a hybrid Mk2 Golf; and
- The use of titanium, ceramics, carbon fibre, kevlar, composites thereof and magnesium is prohibited.

5.5: CHASSIS: (Refer to 5.1)

No chassis stiffening is permitted except that derived from the fitting of the roll cage using only the six mounting feet inside the car, and a 3mm thick plate welded to the chassis to which the cage is bolted [C(c) 10 & 11]. The roll cage must not be fixed directly to the suspension mounting points. Seam welding, strengthening of mounting points and changes in component material of the bodyshell or panels is prohibited. Bodywork repairs to be conducted in structural areas should involve competitor dialogue with the Championship co-ordinator or Eligibility Scrutineer to ensure ongoing bodyshell compliance. Welding of cage to vehicle bodywork is prohibited. Front & rear strut braces are permitted as per regulation 5.8.1.

The following modifications are prohibited:

- Unless specifically authorised in these regulations, the lightening of components or panels in any way, whether via removal of metal or otherwise is prohibited. Specifically but not exclusively this includes removal of any unused bracketry welded to the bodyshell or other components: seat rails, seat front cross member, rear seat base frame, roof tin supports, seat belt anchor backplates, rear seat hinge and retaining brackets.
- Inner wheel arch modification is prohibited and material may not be removed to allow clearance for suspension components, driveshafts and linkages.
- Front turret central cone repositioning.
- Removal of the spare wheel well.
- Removal of bonded metal plugs in the floorpan or other areas of the interior and exterior.

5.6: BODYWORK: (Refer to 5.1)

1. Modifications Permitted:

1. General: Must be of the *standard specification* for the vehicle, with no additions or omissions. Mandatory fitment of laminated windscreen, via rubber seal; bonded windscreen not permitted. Seam welding, strengthening of mounting points and changes in component material are prohibited. Aftermarket glass sunroofs must be replaced as per MSA regulation G129.

2. Interior: Must be of the *standard specification* for the vehicle. Door trims and weather proofing plastic sheets must be removed. Rear quarter panel trims (or rear door trims if 5 door variant), boot side panels, tailgate trim panel and weather proofing plastic sheets must be removed. A basic door trim manufactured from plastic or aluminium only must be fitted to the inside of the driver's door – this must be to a high standard with no sharp edges and a smooth surface. Steering wheel may be changed. Windows must be fully operable – either manual or electric types allowed. Driver's seat must be replaced with a competition seat fitted in accordance with [C(c) 50].

Passenger and rear seats must be removed. Headlining and carpets must be removed. 'Bitumen' sound deadening patches glued to the floor, inner door and other panels may be removed. Internal door latching located within the door cavity may be removed. Rear parcel shelf must be removed. Stereo equipment may be removed. The inner sunroof steel sleeve and mechanism may be removed; the original steel sunroof panel may be permanently attached or replaced by an external steel panel (18 or 20swg) riveted to the roof. Bracketry on the driver's seat crossmember may be removed, but the seat crossmember must remain in place. Trim retaining thread stubs in the boot area and spare wheel retaining pin may be removed. Tailgate struts may be removed. Dashboard fascia must remain *standard* with the exception of minimal material trimming to accommodate rollcage fitment around the A-pillars, but must otherwise remain as originally fitted, aside from the following: dashboard undertrays and centre console may be removed; glovebox lid must remain in place. The car must retain the *standard* de-misting system, which includes an operative interior fan, heater matrix, supplied by water from the car's cooling system. An interior rear view mirror must be fitted to the left of the driver.

3. Exterior: As per *standard specification*. The age of the bodyshell is the reference point for exterior trim requirements throughout these regulations. The bonnet must be secured by surface-mounted bonnet pins; the rear hatch must be secured either by surface-mounted bonnet pins or by suitable clips and locks must remain present but be rendered inoperative. Unless specifically authorised in these regulations, the use, substitution of, and / or addition of, any parts, material or processes is prohibited, other than welding or repairing material or the fitting of *standard* replacement parts, for the sole purpose in every respect of restoring the vehicle to the manufacturer's *standard specification* or to comply with safety requirements. Plastic front wheel arch liners must be removed. Single windscreen wipers are permitted, provided they wipe the full screen. 'Bitumen' sound deadening patches may be removed. Towing eyes must be painted yellow, orange or red and if located within the vehicle periphery, the location must be clearly marked (MSA Regulation G99). All wheel arch spats, door rubbing strips, weather strips/channels must be retained. Two external rear-view mirrors, one on the left hand side and one on the right hand side must be fitted and be a *standard* part pertaining to that model. External fire extinguisher and electrical cut out switches are mandatory, marked as per MSA regulations. Minimum bodywork apertures are permitted for this purpose. Exterior must display all Championship sponsors' decals correctly as communicated by the Organisers. Bumper mountings are free provided the bodywork and the shape and position of the bumpers remain unchanged. It is prohibited to mix and match exterior trim parts on pre-March 1988/post March 1998 model year bodyshells, and also on pre and post 1990 model year bodyshells, except if specifically permitted, in order that the car does not present the image of a hybrid Mk2 Golf. Note that post 1990 models must run the GTI specification lower front bumper skirt. The grille assembly may be modified to increase airflow around the engine compartment but must be outwardly complete. The fitting of air jacks is not permitted.

4. Silhouette: As per *standard specification*.

- a) The exterior of the car must be *standard* for the model being raced.
- b) Only the *standard apertures* in the bodywork may be used for the passage of cooling air. 'Standard apertures' are defined as existing apertures in the bodywork which are open or partially or completely covered by parts authorised for removal in these regulations. To allow the passage of cooling air, the removable parts may be removed. See 5.10:5.1d.
- c) It is not permitted to fit any under-body/under-engine protection other than a fuel tank skid plate (MSA regulation G100).

5. Ground Clearance: It is permitted to alter the ride height. Under no circumstance can any part of the bodywork, or of the suspended part of the car including the exhaust system, be below a horizontal plane passing 75mm above the ground, the car being in normal racing trim with the driver in the normal seated position. A gauge of 75mm may be used by Scrutineers before or after races or practice to check the ground clearance; the vehicle may be stationary or moving during any testing.

2. Modifications Prohibited:

1. General: The exterior of the car must be of *standard specification* for the model being raced. Any replacement body panels must be of *standard* shape, material and thickness. No modifications may be made to, or material removed, from the bodywork or any of its panels including internal stiffeners other than as repairs, apart from the modifications permitted to the sunroof cage in 5.6.1.2.; exterior trim must be *standard*.

2. Interior. Window winding mechanisms may not be removed. Any other modification in contravention of 5.6.1.2 is also prohibited.

3. Exterior: It is not permitted to increase the width of the wheel arch by the addition of material to, or the deformation of, the outside or inside of the wheel arch. No additional holes may be cut into the bodywork or spoiler to aid cooling, brake ducting, air intake etc. Apertures may not be enlarged. Bonnet / engine cover must remain in the normal position and, when closed, must not have any non-*standard* gaps at any of their edges. Fitment of tape etc to close body gaps (e.g. bonnet to wing) is prohibited. The removal of underseal from vehicle wheel arches, and any areas outside the vehicle wheelbase is prohibited.

4. Silhouette: Any in contravention of 5.6.1.4.

5. Ground Clearance: Any in contravention of 5.6.1.5.

5.7: ENGINE: (Refer to 5.1)

Must be of the *standard* type and specification for the exact vehicle – see Table 6.5 - and made of the *standard* material. All components must be used in their *standard* positions, with no additions or omissions unless expressly stated in these regulations. The only modifications permitted to engines are those listed in 5.7.1 (Modifications Permitted) below; if the following texts do not clearly specify that you can do it, you should work on the principle that you cannot. It is the competitor's responsibility to ensure that no prohibited modifications have been carried out, even if they are using an engine not assembled by them.

Control camshaft(s) may be fitted and are to be purchased from the official supplier listed in Appendix 6.2 of these regulations. The camshaft will have unique markings to allow full traceability. Alternatively *standard* camshaft(s) may be used, which require the cam(s) to be sent to the official control camshaft supplier listed in Appendix 6.2 for dimensional checking and the addition of unique markings. Irrespective of camshaft choice, the camshaft(s) must remain entirely unmodified; it is not permitted to re-profile, re-grind or re-manufacture the camshaft(s).

1. Modifications Permitted:

- a) Balancing of the reciprocating parts – minimum removal of material; THIS DOES NOT MEAN LIGHTENING. Flywheel and clutch assembly minimum weight 10.0 kgs, including all flywheel and crankshaft securing bolts, clutch release plate and circlip.
- b) Only 3 pistons / connecting rods may have material removed. Pistons can only have material removed below the gudgeon pin centreline.

- c) Gudgeon pin centreline to piston crown must remain to *standard specification*.
- d) Crankshafts may be reground down to – 0.50 mm. Crankshaft journals must remain within VW positional tolerances if a repair and/or regrind is carried out. Stroke must remain unchanged from *standard specification* (Table 6.5).
- e) Cylinders may be re-bored up to + 1.0 mm using *standard pattern* (in shape, profile and material) unmodified pistons only, specified for the corresponding engine code only.
- f) The cylinder block may have material removed from the upper face up to a maximum of 0.005 inch from *standard* height.
- g) The cylinder head may have material removed from the combustion face up to a maximum of 0.025 inch from *standard* height.
- h) Replacement valves & valve guides may be fitted but must be *standard* or *standard pattern* (in shape, profile and material).
- i) A steel baffled sump and/or Golf diesel-derived windage tray may be fitted. Sump must be externally *standard*.
- j) The *standard* camshaft timing wheel may be replaced by an adjustable item.
- k) Fitment of oil catch tank, of maximum capacity 2 litres (MSA regulation G116 & 117)
- l) Use of aftermarket silicone spark plug leads and HT lead.

2. Modifications Prohibited:

Any other than those permitted in 5.7.1. For clarity:

- a) Cylinder head - MUST remain to *standard specifications*. No material may be added to or removed from the cylinder head; inlet and exhaust ports may not be modified in any way and must remain as cast and as per *standard specification*.
- b) Aside from 5.7:1.f, above, the head casting material cannot be ground, smoothed, welded or in any way altered, whether to achieve optimisation of gas flow or otherwise. Any attempt to alter the shape of the ports, valve throats or the valve seats (i.e. multi angle seats) is prohibited.
- c) *Standard* pistons may not be replaced by forged pistons or 'machined-from-billet' pistons. Piston crowns must not be machined from *standard* in shape or profile.
- d) Valve sizes must not be altered from *standard specification*.
- e) Uprated lifters and lightweight spring caps are prohibited.
- f) Mk3 Golf ABF engine heads (as identified via different castings adjacent to exhaust ports) or head gaskets thereof are not eligible in the 16-valve class.
- g) Fitment of an oil pump from a different production model is prohibited.
- h) Modification of oil pick-up pipe prohibited.
- i) Fitment of a metal head gasket whether sourced from other vehicles within the VW model range, or elsewhere is prohibited.
- j) The use of higher grade aftermarket fasteners for cylinder head, main bearing caps and flywheel – ie ARP or similar – is prohibited.
- k) Fuel injectors cannot be substituted for non-*standard* parts.
- l) The swapping of engine components or any ancillary components between 8-valve and 16-valve engines is prohibited. This is inclusive of any components in the engine bay such as, but not exclusively, pistons, radiator (5.7:4), and electronics.
- m) *Standard* inlet manifold must be retained and may not be modified by the removal or addition of material.

3. Location:

Position and mounting method must be of *standard specification*. An uprated or solid front engine mount may be fitted using *standard* mounting points. All other engine mounts must be of *standard* design and material rigidity grade. Voids in these *standard* engine mounts cannot be filled with any material to attempt to stiffen the mounts. No additional engine/transmission supports may be fitted, whether chassis mounted, or otherwise.

4. Oil/Water cooling: (refer to 5.1)

Water radiators must remain of *standard specification* for the model being raced, in design, size and position. The *standard* radiator fan and fan cowling must also be retained.

1. Modifications Permitted:

- a) An additional oil cooler may be fitted within the overall periphery of the engine bay.
- b) Rubber water hoses may be substituted for silicone aftermarket versions.
- c) Cooling system thermostats may be removed, drilled and/or substituted for versions which open at different temperatures to *standard specification*.
- d) The control system of the radiator fan and the temperature at which the fan cuts in is free. It is permissible to have an additional switch in the cockpit for electronic cooling fans.

2. Modifications Prohibited:

- a) Elimination of water feed to heater matrix.
- b) Electric coolant pumps are not permitted.
- c) Aftermarket lightweight cooling fans.

5. Induction Systems:

The complete induction system must be of the *standard specification* for the vehicle, and be retained in its entirety; it is not permitted to add any covering, whether heat-reflective/heat resistant or not to the inside or outside of any part of the induction system. Components must be used in their *standard* positions, with no additions or omissions except for the following:

Air box may be modified on the atmospheric side of the filter element.

The *standard* panel air filter may be substituted with a modified version of the *standard* size and shape, fitted in the *standard* position. 'Cone' type filters are prohibited. The crankcase breather may vent direct to a catch tank and any holes in the air intake associated with the breather system must be blanked off. No other modifications are permitted.

6. Exhaust systems:

Standard exhaust manifold must be retained and may not be modified by the removal or addition of material. Exhaust systems may not pass through the driver/passenger compartment and must exit at the rear of the vehicle. The remainder of the exhaust system including silencer is free subject to the following:

- a) Constructed of mild or stainless steel only
- b) Variable/adjustable-for-noise exhaust systems prohibited
- c) Exhaust heat wrap is permitted but any form of chemical or ceramic coating on any surface is prohibited
- d) MSA noise regulation [C(b) 23].

7. Engine Management – fuelling, ignition & valve timing:

Components must be of *standard specification* for the vehicle and used in their *standard* positions, with no additions or omissions. Chip alterations within the *standard* ECU are permitted to allow rev limits to be raised. Secondary electronic engine management systems are prohibited. The *standard* ECU may be internally reprogrammed. The use of 'piggy-back' devices in conjunction with the *standard* ECU to modify ignition timing and/or fuelling is prohibited. Fuel lines and fuel filter may be replaced with non-*standard* items. Fuelling, ignition and valve timing may be optimised within the scope of these regulations. Additional sensors are prohibited, aside from those used for auxiliary gauges.

5.8: SUSPENSIONS: (refer to 5.1)

The *standard* specification suspension configuration must be retained and the *standard* mounting points and position of the suspension components to the bodyshell and related suspension units must be used and remain as *standard*. The position of the *standard* top mounts is non-adjustable, and must provide for the suspension strut to centre in its *standard* position. All suspension components (wishbones, hubs, bottom ball joints, suspension top mounts, steering arms, rear beams, anti-roll bars, supports bolted to the bodyshell or subframe) must be *standard*, unmodified and remain in their *standard* position, with no omissions, additions, lightening or modifications allowed to the mounting points and be manufactured from the *standard* material type. No additions or modifications may be made to the mounting points. *Standard* anti-roll bars must be retained, be continuous, and be properly connected. Suspension must be controlled to avoid fouling of

wheels on chassis or bodywork (MSA regulation [C(b) 11]).

Permitted specifications for camber and toe are detailed in Table 6.5.

1. Modifications Permitted:

It is permitted to alter the ride height within the constraints of 5.6:1.5. Spring rates and damper units are free subject to 5.8:2, and may be bump and rebound adjustable, and height adjustable, but three way, or more, adjustable dampers which contain mechanisms for the varied control of damping at different speeds are prohibited. Front suspension top mounts may be changed to *standard* specification parts from Mk2 Golf GTI G60, Mk3 Golf VR6 or Corrado VR6 only; irrespective of the option chosen, the units cannot be modified in any respect. The centreline of the damper unit and spring must run concentrically in the same plane to the *standard* specification, and the king pin angle must be *standard*. Rear dampers must retain rubber lower mounting bushes. Springs must be made of steel and the number fitted must remain the same and be fitted in the same position and orientation as *standard*. It is permissible to fit helper springs to each damper unit. Front camber may be adjusted by using the *standard* manufacturer's system only. Design, material and construction of the upper joints of McPherson suspension parts of the running gear must be *standard* and must bolt to the *standard* mounting points. Front and rear bumpstops are free, provided they are made of rubber or polyurethane (if fitted). A front strut brace attached to the McPherson strut top mounting nuts is permitted. A lower front strut brace, retained using the inner wishbone bolts is permitted.

A single horizontal rear strut brace bolted to the vertical face of the rear inner wheel arch or damper top mounting bolts is permitted. Wishbone, steering rack, front crossmember, rear beam, and rear top mount bushes may be substituted with polyurethane aftermarket versions but must retain all of the *standard* dimensions, designs, positions, fixing centres, and *standard* dimension metal sleeves, and must be used with otherwise *standard* components: polyurethane merely replaces rubber. Wishbone bushes must have rubber or polyurethane in contact with the inner metal sleeve and outer housings. No other bushing materials are permitted.

2. Modifications Prohibited:

Modifications to the suspension pick up points are prohibited; this includes the 'slotting' of top suspension strut mounting points. Offset and/or non-*standard* adjustable suspension strut mounts are prohibited. Modification of the engine subframe or its mounting position prohibited. Spherical joints, rose joints and rod ends are prohibited. Seam welding of front wishbones or engine subframe are prohibited. Ball joint spacers are prohibited. Dampers with separate reservoirs outside the main body of the unit are prohibited. Damper stems must be no more than 28mm in diameter. Front strut inserts may not be fitted inverted such that the body is fixed to the top strut mount. The piston rod must be the fitted uppermost and connect to the top strut mount. Any mechanism for changing the suspension geometry, other than ride height and camber as specified in Table 6.5, within the spring/damper unit is prohibited. Bushes which change the *standard* suspension geometry are prohibited. Anti-roll bars must remain of *standard* specification as per table 6.5. No additional springing medium may be utilised. Rear beams and stub axles must remain *standard* and have geometry as specified in Table 6.5: no strengthening or addition / removal of material is permitted.

3. Wheelbase/track:

Wheelbase and track must remain as *standard* for the vehicle, subject to 5.12.1 and, separately, the acceptance of any minute changes arising solely from adjusting ride height and camber, within the scope of these regulations. Wider front or rear axles from other Volkswagen models are prohibited.

5.9: TRANSMISSIONS: (refer to 5.1)

Must be of the *standard* 020-coded type and specification for the vehicle. See Table 6.5 for permitted ratios and final drive.

1. Modifications Permitted:

A 'short shift' kit fitted externally to the gear linkage is permitted and/or ball and socket replacement gear linkage rods. No other modifications to the gear linkage are permitted. Clutch cover and plate may be changed for uprated *standard* pattern items, permitted clutch diameter is 210mm. Clutches must have sprung centre plates. Flywheel and clutch assemblies may be balanced with minimal removal of material only. Flywheel and clutch assembly minimum weight 10.0 kgs, including all flywheel and crankshaft securing bolts, clutch release plate and circlip. The final drive crownwheel may be secured by either bolts or rivets.

2. Modifications Prohibited:

The method of clutch actuation must not be altered in any way. Limited slip and any other methods of locking or pre-loading the differential are prohibited. The use of any electronic traction control device is prohibited. No electrical connections, switches or sensors may operate on any part of the clutch or gear controls or linkages. For clarity, final drive and gear ratios must remain as per *standard specification* as per Table 6.5 and it is prohibited to mix and match any components. Gearbox casing codes must correspond with the gear ratios contained within.

Gearbox casings cannot be altered by the addition or removal of material, internally, or externally. No modifications to driveshafts or constant velocity joints are permitted. The gearbox must always include a reverse gear, which can be engaged by the driver sitting in his/her seat with his/her safety harness fastened. Only 16-valve cars are permitted to run a gearbox input shaft with 21mm input shaft splines; 8-valve cars cannot use this, irrespective of whether ratios and final drive are correct for the model.

5.10: ELECTRICS (refer to 5.1)

1. Exterior Lighting: To *standard* manufacturer's specification for the vehicle which must all be fully functional, as per MOT requirements. Front lights must be protected in accordance with MSA regulation G127. The inner headlights on 4-headlamp models may be removed and replaced with mesh.

2. Rear Warning Light: An LED rear fog light to EU regulation 7, an FIA homologated LED rear warning light, or an LED stop light to EU regulation 38 is mandatory and must be fitted within 10cms of the centreline of the rear window and be located between the top and bottom edge of the glass. Non integral rear fog lights may be removed. Integral rear fog lights must be rendered inoperative.

3. Batteries: To *standard* manufacturers specification for the vehicle, inclusive of external dimensions and weight; location must be as *standard*. A battery and electric starter motor must be fitted and be capable of repetitive starts. No external (slave) batteries may be used.

4. Generators: A fully working *standard* alternator and *standard* pulley must be fitted and electrically connected so that the *standard* battery charging function is providing a charge to the onboard battery.

5. Electrical and Electronic Systems:

1. Modifications Permitted:

- The central locking system must be disabled and components removed.
- The rear wiper, motor, mechanism and wiring may be removed. Rear washer, plumbing, bottle, wiring and switch may be removed.
- Electric windows may be replaced with manual versions, but must remain fully operational.
- Removal of front fog lamps. Apertures may be sealed or used in accordance with regulation 5.5:4.b.
- Removal of interior light electric components.
- Addition of auxiliary gauges and switches. The main speedometer binnacle must be *standard*. Any openings which result from alterations must be covered.
- Fuses may be added to the electrical circuits. All other electrical and electronic systems must remain in their *standard* positions and be of *standard specifications*.
- Stereo equipment may be removed.
- The *standard* wiring loom must be retained but may be modified by the removal of unused wiring.

2. Modifications Prohibited:

- Substitution of ignition coils with high power ignition coils
- Fitment of non-*standard* distributors
- It is not permitted to install floor or tunnel mounted instrument, fuse and/or switch binnacles.
- Additional electronic devices (such as traction control).

5.11: BRAKES (refer to 5.1)

Must be of the *standard* type and specification for the vehicle and manufactured from the *standard* material. *Standard specification* brake ducting must be removed as far forward as the front spoiler. As per *standard specification*, 8-valve cars must use a 20mm master cylinder and 16-valve cars may use up to a 22mm master cylinder, in conjunction with *standard* servo. Fitting of metal-braided brake hoses is mandatory. The braking system must remain fully operational in all aspects at all times.

1. Modifications Permitted:

Front and rear brake disc backing plates may be removed or deformed. The *standard* brake pads may be substituted with uprated versions of the *standard* size and shape, fitted in the *standard* position. Discs may be replaced by *standard pattern* parts. Brake bias can be optimised using the *standard* components, which must remain unmodified and located in the *standard* position with a *standard* diagonally-plumbed brake line system. All cars with 16 valve engines may use the *standard* specification 256mm front brake assemblies (master cylinder, caliper and disc) from the later 1989-onwards 16-valve models. Discs may be reclaimed by simple machining of the friction faces only, maintaining a minimum disc thickness of 18 mm front, 8 mm rear. Upon replacement, rear brake calipers can be changed to those from a front wheel drive Mk3 Golf GTI.

2. Modifications Prohibited:

- The fitting of any ducting to the brakes is prohibited.
- Anti lock braking systems are prohibited, even if fitted to the vehicle as an option when new.
- Machining of the discs, except as permitted above, is prohibited;
- Grooved, cross-drilled or radially-drilled discs are prohibited.
- Fitment of master cylinders from an 8-valve GTI model to a 16-valve, or vice versa.
- Re-piping of the *standard* diagonally-plumbed brake system to a front-rear set up, and / or fitment of any proprietary brake bias adjuster(s).
- Removal of handbrake system.

5.12: WHEELS / STEERING (refer to 5.1)

Wheels:

1. Permitted Options :

14" or 15" diameter. Maximum rim width 7", offsets must be in the range of ET35 to ET38 only.

Cars must run entire sets of four 14 inch wheels or four 15 inch wheels at any one time.

Wheel retention method must be via bolts. Stud and nut conversions or centre lock wheels are not permitted.

2. Construction & Materials:

Wheels may be light alloy or steel only, of one piece design only.

Magnesium wheels are prohibited. The minimum bare weight of each wheel must be 4.0 kgs for each 14 inch wheel, and 5.1 kgs for each 15 inch wheel. The use of wheel spacers is prohibited.

Steering:

1. General: All suspension and steering components must remain in their *standard* position, with no omissions, additions or modifications allowed to the mounting points and be manufactured from the *standard* material type. The *standard* rack and rack ratio for either *standard* manual or power steering systems, whichever is used, must be retained. Power steering rack if fitted must be fully functional. If fitted with a steering lock, this should be rendered inoperative, unless the vehicle is driven to the circuit on the highway. MSA regulation G112.

1. Modifications Permitted:

Front camber and toe may be changed from *standard* specification (max negative camber = 3 degrees).



2. Modifications Prohibited:

Rear camber and toe must remain *standard* – see 5:8.2 and Table 6.5. For clarification, changes in rack ratio, aside from the manual and power steering racks available, are prohibited. The bending of steering arms at the hub or any other attempt to manipulate bump steer is prohibited.

5.13: TYRES: (refer to 5.1)

1. Specifications:

185/60 x 14" or 195/50 x 15".

2. Nominated Manufacturer: Toyo (R888 range in "GG" Medium Hard compound only).

3. Nominated supplier: As per Appendix 6.1 of these regulations. Competitors are limited to 8 sets of tyres per season. All tyres will be marked upon issue and only these tyres can be used during Timed Qualifying or Race(s). Non compliance will result in penalties as per 4.1 of these regulations being applied.

4. If a tyre is excessively worn or damaged through force majeure, and cannot be replaced from the allocation above, the replacement of any nominated tyre is subject to the prior agreement of the Championship co-ordinator/Eligibility Scrutineer, following inspection of the tyre(s) which were subject to force majeure.

5. Tyre tread depth must be above the 1.6mm legal limit prior to commencement of practice sessions or races.

6. The tyre specification when new must be as supplied by the manufacturer. Tyre buffing is prohibited.

7. The use of any heating / heat retention devices, tyre treatments and compounds is prohibited.

5.14: VEHICLE WEIGHT: (refer to 5.1)

1. Minimum weights (including driver).

Class 1: 8 valve vehicles – 975 kilograms.

Class 2: 16 valve vehicles – 1,025 kilograms.

These minimum weights must be respected at all times during an event. Ballast may be added by a competitor to enable the minimum weight to be reached and must be carried in the car as per 5.14.3.

2. Random checks will be carried out during the season and no driver/car combination is permitted to be below minimum class weight. If any vehicle is underweight at post-practice or post-race scrutineering, penalties as per 4.1 or 4.2 of these regulations will be applied.

3. Ballast must only be added inside the car on the rear passenger footwell using at least 4 mounting bolts with a minimum diameter of 8mm each with steel counterplates at least 400mm² and 3mm thick. The dimensions of the (5kg) ballast plate are as per the drawing in Appendix 6.4 of these regulations; it is the competitor's responsibility to provide and fit their own ballast if it is required. See also MSA regulation [C(b) 21].

5.15: FUEL TANK / FUEL: (refer to 5.1)

1. Types: *Standard* fuel tank must be retained and utilised. Additional baffles or foam in the tank are not permitted.

2. Tank location: *standard*

3. Fuel pump: *standard*

4. Fuel: Only petrol as defined in **The Terminology, Pump Fuel a)** section of the MSA Yearbook for the current year and complying with BS4040, BSEN228 or BS7800 may be used; fuel which exceeds the stated RON (max) levels in Appendix 1 of **The Terminology** is prohibited even if it is sold/promoted as being legal for UK Competition and/or obtainable from 'roadside' pumps. The use of additives by competitors which boost the octane rating (RON) in any petrol is prohibited. At the end of practice and the race at least 3 litres of petrol from the tank of the competing car must be available to the scrutineers for analysis. Compliance with minimum weight for the car will be taken before the petrol is removed.

5.16: SILENCING:

All vehicles must be silenced to current MSA regulations [C(b) 22 & 23].

5.17: NUMBERS & CHAMPIONSHIP DECALS

1. Positions: Race numbers must be displayed on each side of the vehicle alongside the cockpit/driver and as far forward on the front of the vehicle as possible. 750 Motor Club decals must be affixed

prominently near all number backgrounds. Championship Sponsor's decals (where applicable) must be affixed in or near the positions detailed on the diagram supplied with those decals. 750 Motor Club and Championship Sponsor's decals must take preference to any other decals. Failure to comply will render the vehicle and driver ineligible to race.

2. Suppliers: Sponsors and Club decals will be available at the first Championship race in which the vehicle is entered.

6. APPENDICES:

6.1: TYRE SUPPLIER:

Trackside Motorsport, 14 Station Road, Micklegate, Derby. DE3 9GH.
Tel: 01332 516678.

6.2: CAMSHAFT SUPPLIER:

Newman Cams, c/o Trackside Motorsport (to ensure mandatory documentation of cam marking), 14 Station Road, Micklegate, Derby. DE3 9GH. Tel: 01332 516678.

6.3: COMMERCIAL UNDERTAKINGS:

- 1) Acceptance of entry into the Championship is conditional upon each registered competitor and his or her agents, sponsors, team members and all other associated personnel accepting without reservation or recourse to abide by the Golf GTI Championship 2008 regulations and not to act in a manner that could be considered to bring the Championship, and/or its associate companies or sponsors into disrepute.
- 2) Both Car and Driver must meet the requirements of livery during all practice, qualifying and races. Should any vehicle or overalls carry any form of sponsorship or advertising which conflicts in any way with the Championship, associate companies or sponsors, the vehicle may not be permitted to take part in the Championship. The decision of the Championship Organisers in such a situation is final.
- 3) Special care has been taken to leave large areas of the vehicle's surface clear to allow for competitors' sponsors. The Championship Organisers reserve the right to censor any advertising which may be deemed unsuitable.
- 4) The Organisers will supply those livery items referred to in 6.2.1 to ensure the correct location of livery on cars. Note: No additional stickers or livery may appear on the front windscreen of the vehicle other than the designated sponsor's screenstrip which must be fitted without alteration to its appearance.
- 5) In signing the Championship Registration form each entrant agrees that the sponsors of the 2008 Championship may make use of his/her activities, imagery and successes in motor sport for any advertising or promotion with which they are associated.

6.4: BALLAST PLATE DRAWING:

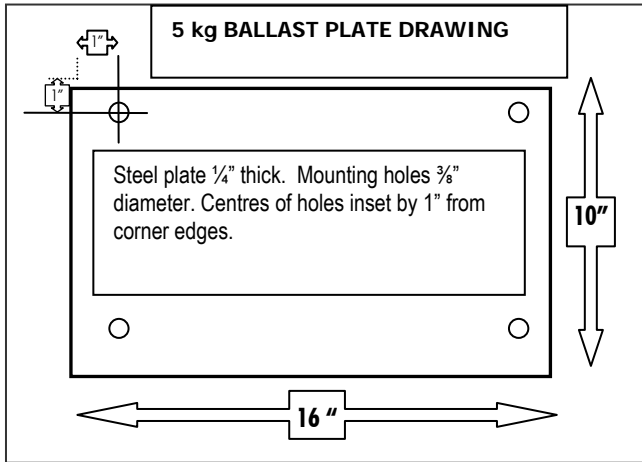

6.5: TECHNICAL SPECIFICATIONS: (refer to 5.1)

Make	Model	Model year	Engine block code	Lifter type	Valve sizes (inlet / exh.)	Injection type	Head Height	Block Height	Compression height	Piston Crown Height	Bore	Stroke (fixed)
VW Golf	GTI 8-valve	1984 – 1985	EV	Solid	38mm / 33mm	K-Jetronic	132.9mm	277.8mm	33.3 +/- 0.05mm	+0.8mm	81mm	86.4mm
VW Golf	GTI 8-valve	1986	EV	Hydraulic	38mm / 33mm	K-Jetronic	132.9mm	277.8mm	33.3 +/- 0.05mm	+0.8mm	81mm	86.4mm
VW Golf	GTI 8-valve	1987 – 1992	PB	Hydraulic	40mm / 33mm	Digifant	132.9mm	277.8mm	33.3 +/- 0.05mm	+0.8mm	81mm	86.4mm
VW Golf	GTI 16-valve	1987 – 1992	KR	Hydraulic	32mm / 28mm	K-Jetronic	159.27mm	277.8mm	34 +/- 0.1mm	+1.2 +/- 0.15mm	81mm	86.4mm

(Model years commence from August in the prior numerical year to that shown).

Camshaft markings: all 8 valve cams - 'MK28V1'; all 16 valves cams - 'MK216V2'

Note: only the above listed engine blocks are eligible. For avoidance of doubt, engine block codes PF, PL, PG, 1H and 3G and any ancillary components where different to the permitted engine codes are not eligible. *Head Height* is measured through cylinder head bolt holes. *Block Height* is measured from top face to bottom face, excluding sump and gaskets. *Compression Height* is measured from crown of piston to gudgeon pin centreline. *Piston Crown Height* is the distance from block deck to highest piston crown point at TDC (excludes chamfered edges, valve cut outs or piston dishes). Note: pistons must be standard pattern in shape, profile and material - 5:7.1e.

TRANSMISSION (note: casing gearbox codes must represent contents; entire sets must be used; hybrid specifications are prohibited)

Model	Model year	Gearbox code	Gearbox Ratios (teeth shown as driven gear/driving gear)					
			Final drive	1 st	2 nd	3 rd	4 th	5 th
GTI 8-valve	1984 -> 1992	9A	3.667 (66/18)	3.455 (38/11)	2.118 (36/17)	1.444 (39/27)	1.129 (35/31)	0.894 (42/47)
GTI 8-valve		ACD	3.667 (66/18)	3.455 (38/11)	2.118 (36/17)	1.444 (39/27)	1.129 (35/31)	0.894 (42/47)
GTI 8-valve		AUG	3.667 (66/18)	3.455 (38/11)	1.944 (35/18)	1.444 (39/27)	1.129 (35/31)	0.894 (42/47)
GTI 16-valve	1987 -> 1992	2Y	3.667 (66/18)	3.455 (38/11)	2.118 (36/17)	1.444 (39/27)	1.129 (35/31)	0.912 (31/34)
GTI 16-valve		AGB	3.667 (66/18)	3.455 (38/11)	2.118 (36/17)	1.444 (39/27)	1.129 (35/31)	0.912 (31/34)

SUSPENSION (note: cambers are per wheel, toe is two wheels combined)

Make	Model	Model yr.	Front toe	Front camber	Rear toe	Rear camber	Front ARB diameter	Rear ARB diameter
VW Golf	8V and 16V	1984 – 1992	Free	-3° max	+25' +/- 15'	-1° 40', +/- 20'	18mm	20mm

Golf GTI Championship 2008
Technical Query Form



Any competitor requiring clarification or rulings on the regulations, should submit their query in writing to the Championship Co-ordinator in order that written confirmation of such clarification or ruling can be produced, if required, at Scrutineering.
Fax No: 01379 741941.

CLARIFICATION REQUEST

DRIVER:

CAR NUMBER:

REGULATION NUMBER:

RETURN FAX NO:

QUERY:

OFFICIAL RESPONSE