



# 750 Motor Club Clio 182 Championship 2015

## Sporting & Technical Regulations



PUBLISHED VERSION - Page 1 of 10 – Issued 03/02/15

### 1: SPORTING REGULATIONS - GENERAL

#### 1.1: TITLE & JURISDICTION:

The **CLIO 182 CHAMPIONSHIP** is organised and administered by the 750 Motor Club Ltd in accordance with the General Regulations of the Royal Automobile Club Motor Sports Association (incorporating the provisions of the International Sporting Code of the FIA) and these Championship Regulations.

1. **MSA Championship Permit No:** CHR2015/R031
2. **MSA Championship Grade:** D.
3. **Race Status:** Clubmans / National B.

#### 1.2: OFFICIALS:

1. **Co-Ordinator:** G.Groombridge, The Conservatory Suite, Donington Park, Castle Donington, Derbyshire, DE74 2RP

☎ 01332 814548; ✉ [giles@750mc.co.uk](mailto:giles@750mc.co.uk).

2. **Eligibility Scrutineer:** M. Lambkin-Smith

3. **Championship Stewards:**

R.Knight                      C. Emmerson                      I.Sowman

#### 1.3: COMPETITOR ELIGIBILITY:

1. Entrants must:
  - (a) be fully paid up valid membership card holding members of the 750 Motor Club and
  - (b) be Registered for the Championship and
  - (c) be in possession of a valid MSA Entrants Licences.
2. Drivers and Entrant/Drivers must:
  - (a) Be current Members of the 750 Motor Club and
  - (b) be Registered for the Championship and
  - (c) be in possession of valid Competition (Racing) National B Licence, as a minimum
  - (d) A professional driver, in possession of a valid Licence (featuring an E.U. flag) and medical, issued by the ASN of a member country of the European Union, or comparable country. ((H)26.2.1. applies)
  - (e) If participation in the Championship requires absence from education a driver, in full time school education is required to have the approval of their head teacher and a letter stating such approval from their school in order to fulfil registration for the Championship. A driver shall not take time out of their education to participate in motor sport without the prior written approval of their education establishment.
3. All necessary documentation must be presented for checking at all rounds when signing-on.

#### 1.4: REGISTRATION:

1. All competitors must register for the championship by returning the Registration Form with the Registration Fee to the Coordinator prior to the Final Closing date for the first round being entered.
2. The Registration Fee is £120 payable upon registration.
3. Registration numbers will be the permanent Competition number for the Championship.

#### 1.5: CHAMPIONSHIP ROUNDS:

The **Clio 182 CHAMPIONSHIP** will be contested over the following rounds:

Date	Circuit	Round/s
25/26 April	Brands Hatch	2
23 May	Croft	2
20/21 June	Cadwell Park	2
1/2 August	Snetterton 200	2
22 August	Silverstone Int	2
12/13 September	Snetterton 300	2
4 October	Donington Park	2

#### 1.6: SCORING:

1. Points will be awarded to Competitors listed as classified finishers in the Final Results as follows:- 25; 22; 20; 18; 16; 14; 12; 11; 10; 9; 8; 7; 6; 5; 4; 3. All other finishers 2. All starters who fail to finish 1.
2. The totals from all qualifying rounds run (excluding any races which are abandoned and which are not replaced) less 2 will determine the final championship points positions.
3. Ties shall be resolved using the formula in (W)1.3.4. in the current

MSA Yearbook.

4. Where the race distance has been reduced (2.6.) it shall still count as a full points scoring round.
5. Competitors not registered for the Championship may be permitted on an individual round basis and will:
  - (a) be deemed "Guest Competitors"
  - (b) not score points and for the purpose of points scoring will be ignored
  - (c) qualify for Event awards
  - (d) comply with the eligibility criteria as prescribed in Article 1.3. above, with the exception of 1.3.1. (b) and 1.3.2. (b), as appropriate

#### 1.7: AWARDS:

1. All awards are to be provided by the Organising Club unless agreed otherwise.
2. Per Round: Trophies to 1st, 2nd and 3rd.
3. Championship: Trophies, subject to a minimum of 5 race starts, to:- 1st, 2<sup>nd</sup>, 3<sup>rd</sup>, 4<sup>th</sup>, 5<sup>th</sup> & 6<sup>th</sup> overall.  
Best Prepared car.
4. Presentations: Awards will be presented at the end of each event, and/or at the end of the Championship at the designated presentation ceremony.
5. Entertainment Tax Liability: {deleted}
6. If Provisional Results or Championship Tables are revised after any presentations and these revisions affect the distribution of awards the Competitors concerned must return them to the organisers in good condition within 7 days.

### 2: CHAMPIONSHIP EVENT MEETINGS & RACE PROCEDURES

#### 1. ENTRIES:

1. Competitors are responsible for sending in correct and complete entries with the correct entry fee prior to the closing date for entries before each event.
2. Incorrect or incomplete entries (Including Driver to be Nominated Entries) are to be held in abeyance until they are complete and correct and the date of receipt for acceptance of entry purposes shall be the date on which the Meeting Organiser receives the missing or corrected information or fee.
3. Any withdrawal of Entry or Driver/Car changes made after acceptance of any entry must be notified to the Meeting Organisers in writing. D25.1.12. applies.
4. The Entry Fee for each event shall be specified in the SRs and on the entry form.
5. Reserves will be listed in the Final List of Entries published with Final Instructions or in a Bulletin.

2. **BRIEFINGS:** Organisers should notify Competitors of the times and locations for all briefings in the Final Instructions for the meetings. Competitors must attend all briefings.

#### 3. QUALIFICATION PRACTICE:

1. Should any Practice session be disrupted the Clerk of the Course shall not be obliged to resume or re-run the session; the decision of the Clerk of the Course shall be final.
2. Each driver shall complete a minimum of 3 laps in the car to be raced, and in the correct session, in order to qualify (MSA Regulations Q4.5).
3. At Double Header Meetings the Grid for Race 2 will be set by second fastest practice times.

4. **RACES:** Should any race be disrupted the Clerk of the Course shall not be obliged to resume or rerun the race ((Q)5.4.) (1.6.4. above applies)

#### 5. STARTS:

1. All cars will be released to form up on the grid prior to the start in formation as specified on the grid sheet.
2. The start will be via Standing start. The minimum Countdown procedures/audible warnings sequence shall be:-
  1. 1 minute to start of Green Flag/Pace Lap - Start Engines/Clear Grid.



# 750 Motor Club Clio 182 Championship 2015

## Sporting & Technical Regulations



PUBLISHED VERSION - Page 2 of 10 – Issued 03/02/15

- II. 30 Seconds - Visible and audible warning for start of Green Flag/Pace Lap.
- III. A five second board will be used to indicate that the grid is complete.
- IV. The red lights will be switched on five seconds after the board is withdrawn.
3. Any car removed from the grid after the 1 minute stage or driven into the pits on the Green Flag lap shall be held in the pitlane and may start the race after the last car has passed the startline or pitlane exit, whichever is the later to take the start from the grid.
4. Any driver unable to start the Green Flag/Pace lap or start are required to indicate their situation as per MSA Regulation (Q)12.13.2. In addition any driver unable to maintain grid positions on the Green Flag Lap, to the extent that ALL other cars are ahead of them, may complete the Green Flag lap but MUST remain at the rear of the last row of the grid but ahead of any cars to be started with a time delay.
5. In the event of any starting lights failure the Starter will revert to use of the National Flag.

**6. SESSION RED FLAG:** Should the need arise to stop any race or practice, RED LIGHTS will be switched on at the Startline and RED FLAGS will be displayed at the Startline and at all Marshals Signalling Points around the Circuit. This is the signal for all drivers to cease circulating at racing speeds, to slow to a safe and reasonable pace and to return to the pit lane, during practice, and to the starting grid area, during a race, unless otherwise directed by officials. Cars may not enter the Pits unless directed to do so. Work on cars already in the Pits must cease when a race is stopped.

### 7. PITS, PADDOCK & PITLANE SAFETY:

- 1 Pits & Paddock: Competitors must ensure that the MSA, Circuit Management and Organising Club Safety Regulations are complied with at all times.
2. Pitlane: The outer lane or lanes are to be kept unobstructed to allow safe passage of cars at all times. The onus shall be on all Drivers to take all due care and respect the pit lane speed limits.
3. Refuelling: May only be carried out in accordance with the MSA General Regulations, the Organising Club Regulations, Circuit Management Regulations and the SRs or Final Instructions issued for each Circuit/Meeting.
4. Speed Limit: Pit Lane Speed Limit will be 60 km/h.

**8. RACE FINISHES:** After taking the Chequered Flag drivers are required to:

- I. progressively and safely slow down
- II. remain behind any competitors ahead of them,
- III. return to the Pit Lane Entrance/Paddock Entrance as instructed,
- IV. comply with any directions given by Marshals or Officials
- V. keep their helmets on and harnesses done up while on the circuit or in the pitlane.

**9. RESULTS:** All Practice Timesheets, Grids, Race Results are to be deemed Provisional until all vehicles are released by Scrutineers after Post Practice/Race Scrutineering and/or after completion of any Judicial or Technical Procedures. (MSA regulation (D)26.3.)

**10. TIMING MODULES:** The 750 Motor Club utilises AMB transponder-based timing and competitors must have a compatible transponder fitted and working and advise the race organisers of its number prior to the event. The transponder is a TRANX 260 Direct Powered and is available from HS Sports Ltd – 01260 275708.

**11. QUALIFICATION RACES:** If any event is oversubscribed the Organising Club may at their discretion run Qualification Races.

**12. OPERATION OF SAFETY CAR: {deleted}**

**13. ONBOARD CAMERAS:** All competitors are required to carry an on board in car camera for the primary purpose of safety. Footage from the

cameras may be used where there is an incident which is subsequently brought before the Clerk of the Course for investigation. The decision to review any such video footage is at the discretion of the Clerk of the Course, the Stewards of the Meeting, the Championship Stewards or the Championship organisers.

- (i) It is the competitor's sole responsibility to ensure safe installation and effective operation of the camera equipment. At all times cameras must be fitted in accordance with MSA Regulations and be approved by the Chief Scrutineer in accordance with J.5.20.5
- (ii) Cameras must mounted in a central to left position with the steering wheel and front windscreen in clear view
- (iii) In the event that no data is available on request (other than due to a proven defect with the equipment) sanctions may be applied which can include but are not limited to exclusion from the Championship or a fine of up to £500. The burden of proof to establish the cause of such failure will lie with the competitor.

### 3: SPECIFIC CHAMPIONSHIP REGULATIONS

In the event of any rounds being oversubscribed the Organising Club may, in liaison with the Championship Coordinator, at their discretion run Qualification races as per 2.11 of these regulations. Alternatively at double header race meetings, should there be sufficient space within the timetable, the Organising Club may divide the grid after qualifying into 3 separate Groups. The Groups will then form 3 races whereby each competitor participates in two races. All 3 races will be eligible for full championship points.

### 4: SPECIFIC CHAMPIONSHIP PENALTIES:

In accordance with Section C of the current MSA Yearbook

#### 4.1: INFRINGEMENT OF TECHNICAL REGULATIONS:

1. Arising from post practice Scrutineering or Judicial Action: Minimum Penalty: The provisions of MSA Regulations: C3.3.
  2. Arising from post race Scrutineering or Judicial Action: Minimum Penalty: The provisions of MSA Regulations: C3.5.1 (a) and (b).
- For infringements deemed to be of a more serious nature the Clerk of the Course will invoke the provisions of Regulation C3.5.1 (c).

#### 4.2: ADDITIONAL SPECIFIC CHAMPIONSHIP PENALTIES:

None

### 5: TECHNICAL REGULATIONS

#### 5.1: INTRODUCTION:

- a) The following Technical Regulations are set out in accordance with the MSA specified format and it should be clearly understood that if the following texts do not clearly specify that you can do it, you must work on the principle that you cannot. The fact that some modifications are mentioned as prohibited does not imply that others are allowed.
- b) **STANDARD:** The word 'standard' used within these technical regulations as a description of components is to be interpreted as per 'Standard Part' defined in Section B – Nomenclature & definitions in the MSA Blue Book. Checking will be by comparison to spare parts supplied by the manufacturer's official agent or by any other means necessary to ensure compliance. It applies to the specified component/s from the manufacturer's parts list for the model / engine shown on the entry form or registration form. No modifications permitted beyond the repair or adjustment processes specifically specified by the manufacturers' workshop manual or microfiche.' Checking will be by comparison to spare parts supplied by the manufacturer's official agent or by any other means necessary to ensure compliance. Where specifications for parts (e.g camshaft, final drive, gear ratios, anti-roll bars etc) are stated within table 6.3 of these regulations, they are mandatory for that make and model of car.
- c) **STANDARD PATTERN:** The words 'standard pattern' used within these technical regulations as a description of components is to be interpreted as per 'Standard Pattern Part' defined in Section B – Nomenclature & definitions in the MSA Blue Book. Checking will be by comparison to spare parts supplied by the manufacturer's official agent or by any other means necessary to ensure compliance.



# 750 Motor Club Clio 182 Championship 2015

## Sporting & Technical Regulations



PUBLISHED VERSION - Page 3 of 10 – Issued 03/02/15

d) Homologation papers, including VO, VK or ES extensions, will not be accepted as proof of specification of any components.

### 5.2: GENERAL DESCRIPTION:

1) The **CLIO 182 CHAMPIONSHIP** is for Competitors participating in the RENAULT 182 CLIO CUP Hatchback Car [Model:CLIO II, Model Type: CB22] available on general catalogued sale and available from stock through normal retail dealer outlets in the UK being only RHD and as specified by the 750 Motor Club Limited.

The engine capacity is 2000cc multi-valve per cylinder. This capacity limit is the original engine size. For validity and procurement of Standard parts [5.1.b and c] the Vehicle Identification Number is: VF1CB220F32892321

There are no restrictions on the trailering of cars to/from the circuit. All vehicles must be of sound construction and mechanical condition and be well maintained. There is no requirement for an MOT Certificate, Road Tax or Insurance. It is the intention of the 750 Motor Club Limited to equalise the performance of the cars by setting minimum weights (5.14.1) and by the addition of ballast (5.14.2). The 750 Motor Club reserves the right to amend the minimum weight specified in 5.14.1 at any stage of the season by giving 7 days notice. It is also the intention of the 750 Motor Club Limited to use other means if necessary to equalise the performance of cars by, for example, rev limiters or air intake restrictors. These restrictions may be imposed on any car and/or driver combination at any stage during the racing season. There is no appeal against the application or addition of ballast or other restrictions. All restrictors/rev limiters will remain the property of the 750 Motor Club Limited and must be returned in good condition to the Competitions Secretary within 2 weeks of the last round of each season.

2) **Examination of vehicles.** The organisers (in addition to any other powers they may have under these regulations) reserve the right before or after any race in the series to designate any one or more of the competing cars for special eligibility scrutineering. Competitors must be prepared, with tools and spare parts as necessary, to enable inspection of components, or to have units sealed at the circuit for later inspection by an Eligibility Scrutineer at the Competitor's expense. Upon such selection being made the competitor shall immediately place the car under the control of the organisers and be deemed to have permitted all such scrutineering, examination and testing as the organisers may reasonably require. The organisers have the right to:

- Examine the car at the circuit for such period as they may reasonably require and take fuel samples.
- Retain the car for detailed examination at premises chosen by the organisers. If the organisers elect to retain the car they shall make it available for collection by the competitor at least seven days prior to the qualification session for the next race in the series unless the car is found to be in breach of these regulations.
- Seal the car and its components in such a manner as they may choose and require the competitor at their own expense to present the car at any other premises chosen by the organisers for detailed examination within a specified period and / or remove the car by transporter at no expense to the competitor to an appointed location. The competitor will be advised in writing of the time, date and location of the subsequent testing or eligibility examination. The overseen stripping of the engine or any required component will be undertaken by the competitor and / or mechanic / technician nominated by the competitor.

### 5.3: SAFETY REQUIREMENTS:

The Articles of MSA Section K Safety Criteria Regulations will apply, and specifically: Six point FIA Bolt In Roll cage, ONLY K Drawing No 5, and compulsory 'side entry' bar on both the driver and passenger side of car to either K drawing No 12g or 12h [recommended] or 9. A Harness Bar (1.1.13) can be fitted as per 1.3.9 to supplement 'Hans' devices ; Seat belts as per K2.1 (not 2.1.2) and FIA homologated ; K2 and K5 – K14; Extinguishers must be plumbed in and comply with K 3.1.2 a); Towing eyes must have a minimum internal diameter of 60mm; (note the tow eye may be of either a suitable rigid or flexible material bolted to the chassis).

### 5.4: GENERAL TECHNICAL REQUIREMENTS & EXCEPTIONS:

All cars must comply with the requirements of sections J and Q19 of the current MSA Yearbook. All vehicles must be of sound construction and mechanical condition and be well maintained. Water hoses, oil hoses and their associated clips are free. Fasteners (eg nuts, bolts) are free. Rose Joints of any type are prohibited [except as fitted to mandatory items]. A SECTION OF ELIGIBILITY GUIDE [TECHNICAL SPECIFICATIONS] (6.0) HAS BEEN PREPARED AND THE CAR MUST COMPLY WITH THOSE SPECIFICATIONS.

The organisers reserve the right to refuse entry from a any car of which the preparation is of a poor standard (including the external appearance) and which is likely to bring the championship into disrepute.

### 5.5: CHASSIS:

No chassis stiffening is permitted except that derived from the fitting of the roll cage using only the six mounting feet inside the car, no other attachment to the bodysell is permitted even if provided by the cage manufacturer. Seam-welding of the shell is prohibited; fitting of a front or rear strut brace is prohibited.

### 5.6: BODYWORK:

(Refer to 5.1.)

#### 1. Modifications Permitted:

- General:** Mandatory fitment of laminated windscreen.
- Interior:** Driver's seat may be replaced. Passenger seat, rear seats, floor coverings, roof lining, detachable boot covers (parcel shelf), radio/stereo units speakers and associated wiring, spare wheel and tools may be removed. Steering wheel may be changed (compulsory if an air bag is fitted as original equipment). Electric window winding mechanisms must be retained; all windows must remain operable and all weather strips/channels must be retained. It is permitted to remove the air-conditioning if fitted [subject to conditions stipulated in 6.4]. An interior rear view mirror must be fitted to the left of the driver. Front door panels may be replaced with aluminium sheeting - this must be executed to a high standard with no sharp edges and with smooth surface. The central locking mechanisms including locking motors must be removed; manual interior door lock mechanisms must be disabled. The standard door latching mechanism must be retained.
- Exterior:** The standard Driver and passenger wing mirror 'pods' must be retained but the choice of mirror within them is free. Plastic front wheel-arch inner liners must be removed. Bonnet and rear hatch locks/latches must be removed along with any auxiliary latch; the bonnet and rear hatch must be fitted with securing pins. The original number of windscreen wiper arms/blades must remain and be fully functioning. Tailgate wiper mechanism and arm/blade must be retained and fully functioning. Front and rear washer systems must be retained and operate. *Headlamp washers must be removed and holes covered.* No other alterations to standard. All weather strips/channels must be retained. Suitable flat mounting plates 510mm x 115mm high ( $\pm$  5mm on both dimensions) must be fitted to the normal number plate positions front & rear to carry championship decals as issued by the 750MC.
- Silhouette:** No alterations to standard.
- Ground Clearance:** It is permitted to alter the ride height. Under no circumstance can any part of the bodywork, or of the suspended part of the car [excluding the exhaust system], be below a horizontal plane passing 75mm above the ground, the car being in normal racing trim with the driver aboard. A gauge of 75mm may be used by Scrutineers before or after races or practice to check the ground clearance; the vehicle may be stationary or moving during any testing.

#### 2. Modifications Prohibited:

- General:** The exterior of the car must be standard for the model being raced. Any replacement body panels must be of original shape, material and thickness. The reduction in thickness of any part of the car by acid-dipping, blasting or by any other means is prohibited. No modifications may be made to or material removed from the bodywork



# 750 Motor Club Clio 182 Championship 2015

## Sporting & Technical Regulations



PUBLISHED VERSION - Page 4 of 10 – Issued 03/02/15

or any of its panels including internal stiffeners other than as repairs; exterior trim must be generally standard.

**2. Interior:** Rear passenger side panels, Tailgate trim panel, Rear boot trim panel may not be removed. Driver and passenger upper mirror and rear window trim panels may not be removed. Any other modification in contravention of 5.6.1.2 is also prohibited. The Handbrake cover and Gearlever cover to dash must be retained. The dash fascia/instrument cluster must remain as originally fitted with the exception of immediately localized trimming for the fitment of the rollage.

**3. Exterior:** It is not permitted to increase the width of the wheel arch by the addition of material to, or the deformation of, the outside or inside of the wheel arch. Additional holes for cooling, brake ducting, air intake etc may not be made in the bodywork. Bonnet / engine cover must remain in the normal position and, when closed, must not have any non-standard gaps at any of their edges. Standard fitment auxiliary lights must be removed, and can be replaced with Renault blanking plates [Renault part: 7701209099] or mesh. Fitment of tape etc to close body gaps (e.g. bonnet to wing) is prohibited. Recessed bonnet & rear hatch securing pins are prohibited.

**4. Silhouette:** Any in contravention of 5.6.1.4.

**5. Ground Clearance:** Any in contravention of 5.6.1.5.

### 5.7: ENGINE:

The only permitted engine is the Renault Clio 182 type F4R 738. All engine parts must be standard for the Vin : VF1CB220F32892321.

#### 1. Modifications Permitted:

- 1.1 The replacement of valves, valve guides and valve seats with parts of standard pattern and material is permitted.
- 1.2 The replacement of engine mountings, upper engine, upper gearbox and lower stabiliser link with only the parts listed and supplied by K-Tec Racing as per 6.5.4.

#### 2. Modifications Prohibited:

**Any other than those permitted in 5.7.1. The maximum permitted compression ratio is 11.0:1.**

**Checking will be by comparison to spare parts supplied under VIN:VF1CB220F32892321 by the manufacturer's official agent or by any other means necessary to ensure compliance.** The camshaft must remain entirely unmodified; it is not permitted to regrind or re-profile or grind from blanks. The standard cambelt cover/s must be retained.

**3. Location:** Position and mounting method must be standard for the model being raced. No additional engine/transmission support may be fitted.

**4. Oil/Water cooling:** The water radiators must remain standard in design and position with no additional air ducting. An oil cooler may be fitted within the overall periphery of the engine bay; no additional air ducts are permitted. Internal baffles may be fitted to the standard sump; the sump oil pick-up pipe may be modified.

**5. Induction Systems:** The complete standard induction system must be retained in its entirety; it is not permitted to add any covering, whether heat-reflective/heat-resistant or not, to the inside or outside of any part of the induction system. Air filter elements may be removed or replaced by non-standard filter elements inside the standard casing. No other modifications are permitted. The crankcase breather may vent direct to a catch tank and any holes in the air filter housing associated with the breather system may be blanked off.

**6. Exhaust systems:** The complete standard exhaust manifold must be retained in its entirety.

The Twin pipe exhaust system must exit at the rear of the vehicle as standard for the Clio CB22 model type [see silhouette 5.6.1.4]. Exhaust systems may not pass through the driver/passenger compartment. The remainder of the exhaust system including silencer(s) is free but no part of the manifold, piping or silencer may have any covering or

lagging, whether heat resistant, heat reflective or not.

The vehicle must be fitted with a catalytic converter in the exhaust system, that the exhaust gases must pass through.

The standard heat deflector plates fitted to the underside of the body must be retained for the full length of the exhaust system.

**7. Ignition systems:** It is a mandatory requirement to *only fit and run the Clio series Engine Control Unit [ECU] Part Number KTRGEN90R750. The ECU is 182 specific supplied pre-mapped and locked with diagnosis and initial setup software and comms lead. The sole supplier is K-Tec Racing, for supplier details see 6.5.* The ECU is a sealed item and all seals must remain intact at all times. For ECU repairs or Servicing use only the Sole Supplier. The organisers can at any time before or after a race or practice replace the competitors ECU with their own sealed unit, swap competitors ECU's between cars. No alternative or additional ECU is permitted. Plug leads and Spark plugs are free. No additional sensors are permitted. Only the standard sensors as detailed in 6.5 are permitted. Sensors must be fitted in standard positions. The second oxygen exhaust sensor after the Catalytic converter can be removed as it is not used by the ECU. The air inlet 'cold start' flap can be removed or locked in the fully open position as the function is not used by the ECU.

**8. Fuel delivery systems:** It is permissible to replace only the fuel lines, and filter with non-standard items. The engine fuel gallery shield block must be retained and fitted [part 8200110830]

### 9: Additional Specific regulations

**9.1 ESP at present must be disabled at all times.**

**9.2 Charcoal filter may be removed.**

### 5.8: SUSPENSIONS:

**(Refer to 5.1).** The original suspension configuration must be retained. Standard Front anti-roll bar must be retained and be properly connected. Standard chassis bump-stops must be fitted in the standard position.

**1. Permitted modifications:** It is permitted to alter the ride height within the constraints of 5.6.1. It is a mandatory requirement for all cars to run with the *K-Tec Racing Clio Series specification front and rear coil-over suspension kit Part Number KTRSX9005 and Front Top Mounts 050/KIT/KTR/002. For supplier details see 6.5.* All the items [and Bumpstops] supplied *with the K Tec suspension kit* must be utilised. For Mandatory suspension Repairs or Servicing use only the Sole Supplier. Only the adjustability of Front Tracking [toe in and toe out] *and Front camber [see 6.3] within the Mandatory suspension dampers* is permitted. The organisers can at any time before or after a race or practice replace the competitors Mandatory suspension items with their own sealed units and springs. Springs are fixed for length and rate.

**5.8.1.1** *A Renault recognised Modification to the front top chassis suspension mounting may of occurred [enlarging the shock-absorber mounting hole], and thus the mandatory Front Top Mounts may be difficult to fit. It is permitted to weld [fit] a top mount plate manufactured to the dimensions shown in 6.7.2, onto the top of the front top chassis suspension mounting in the position shown in 6.7.3.*

**2. Prohibited modifications:** Modifications to any of the suspension pick-up points are prohibited [except as in 5.8.1.1 above]; *this includes the 'slotting' of any suspension mounting points.* Cockpit adjustable anti-roll bars are prohibited. Offset and/or adjustable suspension strut mounts are prohibited. Adjustable hub-carrier brackets are prohibited, even if the adjustability is disabled. Rear anti-roll bar is prohibited, non-standard suspension bushes are prohibited; rose joints, rod ends or similar are prohibited. Any modification which prevents a wheel from reaching its fully drooped position is prohibited. Use of any 'packing' or 'plates' is also prohibited.

**3. Wheelbase/track:** The wheelbase and track must be standard **as detailed in 6.3.**



# 750 Motor Club Clio 182 Championship 2015

## Sporting & Technical Regulations



PUBLISHED VERSION - Page 5 of 10 – Issued 03/02/15

### 5.9: TRANSMISSIONS:

(Refer to 5.1).

Gear selection and clutch operation must be purely mechanical, standard for the CB22 model type, and solely under direct control of the driver. No electrical connections may operate on any part of the clutch or gear controls or linkages. Note CB22 model does have a clutch switch, that is not used by the control ECU, this can be retained but must not have any other electrical or electronic device connected to it *weather by wires/wireless/magnetic means*.

**1. Permitted modifications:** None. Standard gearbox and final drive/axle for the CB22 model type must be retained as detailed in 6.3. Clutch cover and plate may be changed for updated standard pattern items.

**2. Prohibited modifications: Any other than those permitted in 5.9.1.**

**3. Transmissions & Drive ratios:** The use of any electronic traction control device is prohibited. Standard gearbox ratios and final drive ratios for the CB22 model type must be retained.

### 5.10: ELECTRICS

**1. Exterior Lighting:** Must be as per standard fitment and to EC requirements and be fully operational to MOT requirements. Lights must be taped to MSA regulations.

**2. Rear Warning Light:** An LED rear fog light to EU regulation 7, an FIA homologated LED rear warning light is mandatory and must be fitted within 10cms of the centreline of the rear window and be located between the top edge of the tailgate and bottom edge of the tailgate glass. Integral rear fog lights must be rendered inoperative.

**3. Batteries:** No restrictions on type subject to MSA regulations; location must be as standard. A battery and electric starter motor must be fitted and be capable of repetitive starts. No external (slave) batteries may be used.

**4. Generators:** A fully working standard alternator/generator and standard pulley must be fitted and electrically connected so that the standard battery charging function is providing a charge to the onboard battery.

**5. Wiring:** The original standard wiring loom must be retained except as detailed in 5.6.1.2. Wiring can be added to meet 5.3, 5.4, 5.10.2 and to furnish Lap Timers, and extra gauges.

### 5.11: BRAKES

**ABS.**

*There are two options, Option 1 for ABS as Standard, Option 2 Non-ABS. The Choice is either all Option 1 OR all Option 2, no combination of both options is permitted.*

**OPTION 1:** *The Renault Clio 182 cup [CB22] is fitted with ABS as standard, this must remain standard and fully functioning with all original wheel sensors, ECU, pump and brake piping configuration. No modifications to the standard factory fitted system are allowed except as detailed in 5.11.1 below.*

**OPTION 2:** *The original ABS pump can be removed [NOT the ABS ECU] and brake piping configuration can be re-configured, but must have as mandatory the Tilton screw type proportioning valve [brake bias valve] part number 90-2000 fitted between the master cylinder and all rear brake wheel cylinders. The Mandatory Brake Bias valve location is free. The wheel sensors, wiring and ABS ECU must be retained and fully functioning as standard. Permitted modifications as 5.11.1 below.*

**1. Permitted Modifications:** Non-standard linings. Fitting of alternative brake piping/hosing. Discs may be replaced by standard-pattern 'non-genuine' parts. The braking system must remain fully operational in all aspects at all times.

**2. Prohibited Modifications:** Discs / drums may not be cross-drilled or grooved. Any hydraulically-operated handbrake is not permitted.

### 5.12: WHEELS / STEERING

**1. Wheels :** It is a mandatory requirement to only use the 'Pro Race 1.2' wheels supplied by Rimstock Plc as per 6.5.5. Colour is free.

**STEERING LOCK:** The steering lock should be rendered inoperative, unless the vehicle is driven to the circuit on the highway. MSA regulation Q19.6.

**2. Prohibited Options.** None of the VO, VK or ES extensions in the vehicle's homologation papers is permitted.

**3. Construction & Materials:** Not applicable; wheels must be as 5.12.1.

**4. Dimensions:** TBD

### 5.13: TYRES

**1. Specifications:** Tyres must be road-legal in every respect to MOT requirements at any time. The use of tyre heating/heat retention devices, tyre treatments and compounds is prohibited. No alteration to the tyre from the manufacturer's specification is permitted. Re-cutting, re-grooving or in any other way modifying the tread pattern is not permitted. All the manufacturer's data must be clearly visible. Buffing of sidewalls to remove data is prohibited.

**2. Nominated Manufacturers:** It is a mandatory requirement to only use the 195/50R15 Dunlop DZ03G R1 tyre supplied by Mr Tyre (Motorsport) Ltd [see 6.5.6]

**Nominated supplier:** See 6.5.6.

### 5.14: VEHICLE WEIGHT:

**1.** A minimum weight including driver is set at 1070kgs. All minimum weights are including driver and race overalls, helmet etc. Random checks will be carried out during the season and no car/driver combination shall be below this minimum weight. Ballast must be added by competitors in accordance with 5.14.2 and must be carried in the car as per 5.14.3.

**2.** Ballast must be added (or deleted) after each series round, including 'double-headers'. 30 Kgs will be added for 1st place. 20Kgs will be added for 2nd place. 10 Kgs will be added for 3rd place. 5 Kgs will be added for 4th place. Ballast will be limited to the cumulative total of the last three race finishes – a 'DNF' does not count as a race finish. Ballast applies to the car and driver. A change of driver or car will have no effect on the amount to be carried. An initial minimum of 10 Kgs ballast accumulation is required before the first ballast is physically added to the car. If any vehicle is underweight at post-race scrutineering, penalties as per 4.1 of these regulations will be applied.

**3.** Ballast must only be mounted inside the car on the front or rear passenger floor area. It is the responsibility of the competitor to provide and fit their own ballast as per the drawing in the Appendix 6.2 and to mount it to the satisfaction of the scrutineers. (Care should be taken in the mounting, by use of suitable 'spreader plates' and appropriate size and quality of bolts with reference to MSA regulation J5.15.

### 5.15: FUEL TANK / FUEL

**1. Types:** Either Standard fuel tank or Mandatory Alloy Tank supplied by Bucks Automotive Ltd [see 6.5.3] both with standard components fitted to the CB22 model type. Any other fuel tank type and components fitted are prohibited. No modifications are permitted to the standard fuel tank. A non-return valve must be incorporated in the vent system. Note: MSA regulation Q 19.1.4 applies to the CB22 standard model type fuel tank and Mandatory Alloy Tank.

**2. Locations:** Fuel tanks must be mounted in the standard manufacturers position.

**3. Fuel:** Only petrol as defined in Section B Nomenclature & Definitions, **Pump Fuel a)** section of the MSA Yearbook for the current year and complying with BS4040, BSEN228 or BS7800 may be used; fuel which exceeds the stated RON (max) levels in Appendix 1 of Section B Nomenclature & Definitions is prohibited even if it is sold/promoted as being legal for UK Competition and/or obtainable from 'roadside' pumps. The use of additives by competitors which boost the octane rating (RON) in any petrol is prohibited. At the end of practice and the race at least 3 litres of petrol from the tank of the competing car must be available to the scrutineers for analysis. Compliance with minimum weight for the car will be taken before the petrol is removed.



# 750 Motor Club Clio 182 Championship 2015

## Sporting & Technical Regulations



PUBLISHED VERSION - Page 6 of 10 – Issued 03/02/15

**Note:** The mandatory ECU is designed to run on 100 RON with NO additives.

### 5.16: SILENCING:

All vehicles must comply with the relevant maximum noise limits set out in MSA Blue Book regulation J. Chart 5.18.

### 5.17: NUMBERS & CHAMPIONSHIP DECALS

**1.Positions:** The race numbers for each rear side window shall be;

- (i) A minimum of 200mm high
- (ii) With a stroke width of at least 20mm
- (iii) Coloured reflective yellow.

In addition, the windscreen of all cars must display the competition number positioned on the upper area of the passenger's side of the windscreen, as follows;

- (i) The numerals must be at least 150mm high
- (ii) Be in the same colour and font as those displayed on the rear side windows
- (iii) Be placed no closer than 50mm from the lower edge of the windscreen "sun-strip" and 50mm from the side edge of the windscreen.

750 Motor Club decals must be affixed prominently. Series Sponsor's decals (where applicable) must be affixed in or near the positions detailed on any diagram supplied with those decals. Cars will also be required to carry 750MC series decals on front & rear number plates in the normal number plate position. 750 Motor Club and series Sponsor's decals must take preference to any other decals. Failure to comply will render the vehicle and driver ineligible to race.

**2. Suppliers:** Sponsors and Club decals will be available at the first series race in which the vehicle is entered. Competition numbers will be obtained at the competitor's expense.

### 6. APPENDICES:

**6.1. ELIGIBILITY GUIDE:** Renault Clio 182 Cup, model: Clio II, model type: CB22, VIN: VF1CB220F32892321.

6.2 ESP. This must be disabled when racing, other details TBA.

#### 6.3

Wheelbase: 2485mm ± 10mm

Rear Camber: -1°30' ±20'

Rear Track: 1408 ± 2mm Rear Toe: Toe in 0°54' ±50'

Front Track: 1430 ±2mm Front Toe: free.

Front Camber: -1° to -3.5°

Front Castor: 3° ±30'

King Pin: 12°50' ± 30'

Brake Disc Diameters.

Front: 280 mm. Rear: 238 mm

Front Antiroll bar Diameter: 25.2 ±0.05mm . Renault Part Number: 8200104120

Gearbox: Type JC5, suffix 130

#### Ratios

1<sup>st</sup> 11:34

2<sup>nd</sup> 22:41

3<sup>rd</sup> 28:37

4<sup>th</sup> 34:35

5<sup>th</sup> 39:31

Final drive: 15:61

#### 6.4 Air conditioning

It is permitted to remove the air conditioning components in the engine bay with the following Renault parts:

1 off	7703002855	M10X Vis Embase
1 off	8200821816	Belt
1 off	7703033159	Nut M6x100
1 off	7700104128	Adjusting Bolt

1 off	7703002680	M8x1 Vis Embase
1 off	7700868118	Support Pump
1 off	8200031832	Bracket Altern C2
4 off	7703002847	Washer

1 off Alternator, Renault Part number 401745451, or of genuine aftermarket equivalent.

The Control Unit in the dashboard must be retained with all the associated wiring.

6.5

6.5.1 ECU Supplier. *[Mandatory]*

The mandatory ECU supplier is K-Tec Racing.

ECU Part Number: *KTR GEN90R750 Priced at £850+ VAT*

*K-Tec Racing*

*Bournemouth Road*

*Charlton Marshall*

*Dorset*

*DT11 9NE*

*Tel: 01258 456961*

*Email:sales@k-tecracing.com*

Mandatory ECU Engine sensors: Renault Part numbers..

Water Temperature sensor: 8200561449

Air Temperature sensor: 7700101451

Knock Sensor: 7700866055

Line pressure sensor: 8200121800 or 8200719629

TDC sensor: 8200468645 or 8200647554

Throttle Body: 8200110994

Crankshaft sensor: N/A

Injectors: 7700109254

Fuel pump/sender: 8200057324

EGO [oxygen sensor]:7700107433

6.5.2 Suspension supplier. *[Mandatory]*

*K-Tec Racing Clio Series specification front and rear coil-over suspension kit [four dampers + four springs]Part Number KTRSX9005 Priced at £850+VAT, and Front Top Mounts 050/KIT/KTR/002 Priced at £139+VAT.*

*K-Tec Racing*

*Bournemouth Road*

*Charlton Marshall*

*Dorset*

*DT11 9NE*

*Tel: 01258 456961*

*Email:sales@k-tecracing.com*

6.5.3 Fuel Tank Supplier. *[Optional]*

*Part Number:8200 264 182*

*Bucks Automotive Ltd*

*36 Edison Road,*

*Rabans Lane,*

*Aylesbury,*

*Bucks HP19 8TE*

*Tel: 01296 337482*

6.5.4 Engine Mountings Supplier. *[Optional]*

*Upper Engine Mount: 030/EXT/ENG/0018, £79.00 + vat*

*Upper Gearbox Mount: 030/EXT/ENG/0019, £79.00 + vat*

*Lower Stabiliser Link: 030/EXT/ENG/012, £59.00 + vat*

*K-Tec Racing*

*Bournemouth Road*



### 6.7: Drawings

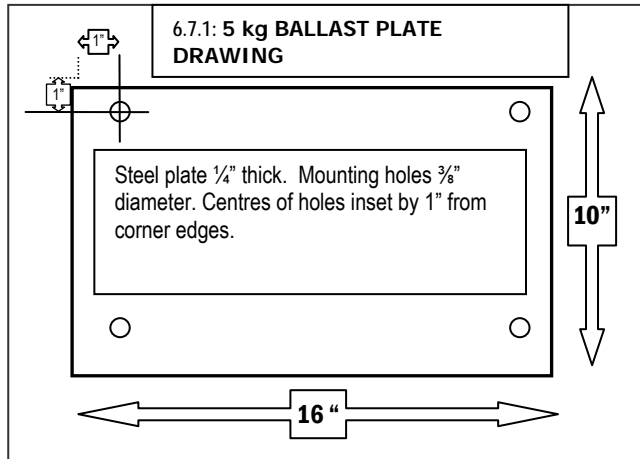

### 6.7.3 TOP MOUNT PLATE POSITION [Ref:5.8.1.1]

#### Nearside View.

Dimensions in mm  
Tolerance +/- 0.5mm

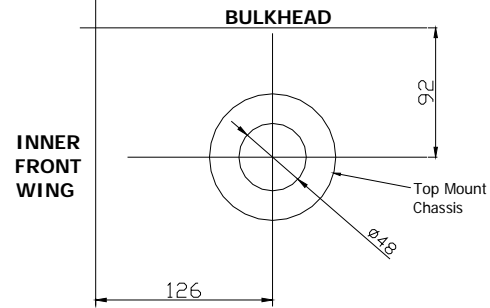

Repeat Mirror image for OFFSIDE.

### 6.7.2 TOP MOUNT PLATE [Ref:5.8.1.1]

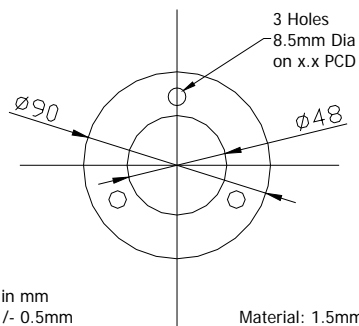

Dimensions in mm  
Tolerance +/- 0.5mm

Material: 1.5mm thick steel.

'x.x PCD' is 63.0mm +/- 0.1 mm



## Guidance Notes.

The Model type and especially the Vin must be used to ensure the competitors vehicle conforms to the regulations, and can also be used to acquire the correct spare parts.

The control ECU is designed and programmed to provide the optimum engine performance with the sensors listed, and with a standard component engine with a compression ratio of 11:1, running on pump fuel. By not using the specified standard parts or deviating in any way the engine performance will be reduced, and may result in permanent damaged. Also the ECU is capable of Data-logging, with most of the data being available to Scrutineering only. It is also capable of providing the competitor with fault coding and certain other data.

The series requires the eligible car to be the 182 CUP variant, however a 182 sport can be used provided the CUP options are fitted, pertaining to the Front suspension Hubs, flanges, and drive-shafts, front splitter and rear wing. Other 'CUP' requirements on trim and accessories are not perceived as relevant and thus do not need to be evident.

It is NOT considered viable to upgrade 172 type cars to the 182 CUP requirement.

Air conditioning, as stated can be removed, but only the compressor and radiator and associated piping in the engine bay. A kit of replacement parts is listed as mandatory to provide a reliable and compliant modification so each car is the same and easily policed. There are 'other' kits and methods that have and are proving to be very un-reliable and damaging engines when used in motorsport.

ESP must be disabled when racing, and at the moment this has to be selected by the driver, until a secure method is found.

ABS, two options its either you comply to option 1 or option 2 there is no combination allowed. The facts have confirmed the original concern and thus its either full standard ABS or Non ABS but the fitting of a mandatory brake bias valve for the rear brakes to avoid lock up but also to comply with MSA regulations requiring the 25% braking to the rear wheels.

The ABS ECU will remain operational with both options, and the standard wheel sensors have to be fitted and working. The Engine ECU uses the wheel sensor data and ABS ECU interface, and Scrutineering can access this data to ensure function and gearbox/final drive ratio.

Tyres, the original AD08 proved to be inadequate, replaced by any 1A/1B tyre, however the only size that gave the best performance was the Kumo. There is a lack of suitable options for the 205/45 size on standard rims. Cost then becomes an issue with kumo's with no other choice. To get a cheaper tyre the wheel rim size has to change so in the interest of cheaper high performance tyre, the new rims were selected to support the 195/50 dunlop tyre. Its calculated over a season that this option will reduce tyre cost by over £600 [4 sets of tyres + new rims], and the old wheels can be sold off getting another £150+ back. So the tyres become mandatory as do the wheel rims.

It is still allowed to 'Buff' the tyres but the dunlops don't really need it at all.

Gearbox ratios are stipulated, so ensure the gearbox fitted is the correct type JC5 suffix 130, as it can be checked electronically.

There are 'other' useful Renault part numbers listed to determine the exact part requirement for the race car eligibility.

The Roll Cage type has been clarified, ONLY diagram 5, with one single diagonal, any other type is not allowed. There are 3 door bar options, and the harness bar allowed for [hans].

Engine mounts: It is clear the standard engine mounts do degrade over racing, so the option to use upgraded types is allowed, as well as standard, but it is either/or, no combinations.

Fuel tank, During the 2013 season fuel starvation/surge has been an issue. This is due to the standard tank being too large and spread out. Using 'foam' can reduce the issue, but it needs to be carefully fitted and plenty of it circa 130 pounds worth, and this may not fully alleviate the problem, and inhibits the fuel sender function [fuel gauge]. Therefore a second option has been created in the form of a smaller custom built tank, with 25 litres that fits in the standard position, uses all the standard components, and allows fuel sender [petrol gauge] to function. This is an option available through the Bucks Automotive Ltd. POA

Race numbers on rear windows etc, allows more door space for graphics and possible sponsors, and it also looks good, see compact cup.

Ballast added, as we now expect higher entry numbers, and thus need to peg back runaways.

No car picture as yet determining decals, however there will be a single front windscreen decal, 750MC decals, and three sponsor decals requiring space on the Clio. Number plate size panels, front and rear are mandatory to carry the series identity.

**ITS VERY SIMPLE, IF IN DOUBT ASK.**

