



1: SPORTING REGULATIONS - GENERAL

1.1: TITLE & JURISDICTION:

The **LOCOST CHAMPIONSHIP** is organised and administered by the 750 Motor Club Ltd in accordance with the General Regulations of Motorsport UK (incorporating the provisions of the International Sporting Code of the FIA) and these Championship Regulations.

- MOTORSPORT UK Championship Permit No: CH2019/**
- MOTORSPORT UK Championship Grade: C.**
- Race Status:** Clubmans / National B.

1.2: OFFICIALS:

1. Co-Ordinator: G.Groombridge, The 750 Motor Club, Donington Park, Castle Donington, Derbyshire, DE74 2RP

☎ 01332 814548; ✉ giles@750mc.co.uk.

2. Eligibility Scrutineer(s): R. Blackmore A. Dorell

3. Championship Stewards:
R.Knight C. Chapman I.Sowman

1.3: COMPETITOR ELIGIBILITY:

1. Entrants must:

- be fully paid up valid membership card holding members of the 750 Motor Club and
- be Registered for the Championship and
- be in possession of a valid MOTORSPORT UK Entrants Licences.

2. Drivers and Entrant/Drivers must:

- Be current Members of the 750 Motor Club and
 - be Registered for the Championship and
 - be in possession of valid Competition (Racing) National B Licence, as a minimum
 - A professional driver, in possession of a valid Licence (featuring an E.U. flag) and medical, issued by the ASN of a member country of the European Union, or comparable country. ((H)26.2.1. applies)
 - If participation in the Championship requires absence from education a driver, in full time school education is required to have the approval of their head teacher and a letter stating such approval from their school in order to fulfil registration for the Championship. A driver shall not take time out of their education to participate in motor sport without the prior written approval of their education establishment.
- 3. All necessary documentation must be presented for checking at all rounds when signing-on.**

1.4: REGISTRATION:

- All competitors must register for the championship by returning the Registration Form with the Registration Fee to the Coordinator prior to the Final Closing date for the first round being entered.
- The Registration Fee for the season is £130 payable upon registration. For competitors wishing to enter a single event a registration fee of £25 is payable **and points will be awarded for this event**. If further races are entered the balance of the £130 fee must be paid.
- Registration numbers will be the permanent Competition number for the Championship.

1.5: CHAMPIONSHIP ROUNDS:

The **LOCOST CHAMPIONSHIP** will be contested over the following rounds:

Date	Circuit	Round/s
------	---------	---------

1.6: SCORING:

- Points will be awarded to Competitors listed as classified finishers in the Final Results as follows:- 25; 22; 20; 18; 16; 14; 12; 11; 10; 9; 8; 7; 6; 5; 4; 3. All other finishers 2. All starters who fail to finish 1. Fastest Lap 1 point.
- The totals from all qualifying rounds run (excluding any races which are abandoned and which are not replaced) less 3 will determine the final championship points positions.
- Ties shall be resolved using the formula in (W)1.3.4. in the current MOTORSPORT UK Yearbook.
- Where the race distance has been reduced (2.6.) it shall still count as a full points scoring round.
- Competitors not registered for the Championship may be permitted on an individual round basis and will:
 - be deemed "Guest Competitors"
 - not score points and for the purpose of points scoring will be ignored
 - qualify for Event awards
 - comply with the eligibility criteria as prescribed in Article 1.3. above, with the exception of 1.3.1. (b) and 1.3.2. (b), as appropriate
- Where two drivers are registered in the Team Challenge and are sharing a car, their points scored (as per 1.6.1) will be combined and they will compete for the Team Challenge Awards as per 1.7.3. Each driver must contribute at least 4 scores to the team total.

1.7: AWARDS:

- All awards are to be provided by the Organising Club unless agreed otherwise.
- Per Round: Trophies to 1st, 2nd and 3rd.
- Championship: Trophies, subject to a minimum of 5 race starts, to:-
1st, 2nd, 3rd, 4th, 5th & 6th overall.
Best Prepared car.
Team Challenge trophy for the team with the highest scores as described in 1.6.8.
- Presentations: Awards will be presented at the end of each event, and/or at the end of the Championship at the designated presentation ceremony.
- Entertainment Tax Liability: {deleted}
- If Provisional Results or Championship Tables are revised after any presentations and these revisions affect the distribution of awards the Competitors concerned must return them to the organisers in good condition within 7 days.

2: CHAMPIONSHIP EVENT MEETINGS & RACE PROCEDURES

1. ENTRIES:

- Competitors are responsible for sending in correct and complete entries with the correct entry fee prior to the closing date for entries before each event.
- Incorrect or incomplete entries (Including Driver to be Nominated Entries) are to be held in abeyance until they are complete and correct and the date of receipt for acceptance of entry purposes shall be the date on which the Meeting Organiser receives the missing or corrected information or fee.
- Any withdrawal of Entry or Driver/Car changes made after acceptance of any entry must be notified to the Meeting Organisers in writing. D25.1.12. applies.
- The Entry Fee for each event shall be specified in the SRs and on the entry form.
- Reserves will be listed in the Final List of Entries published with Final Instructions or in a Bulletin.

- BRIEFINGS:** Organisers should notify Competitors of the times and locations for all briefings in the Final Instructions for the meetings.



Competitors must attend all briefings.

3. QUALIFICATION PRACTICE:

1. Should any Practice session be disrupted the Clerk of the Course shall not be obliged to resume or re-run the session; the decision of the Clerk of the Course shall be final.
2. Each driver shall complete a minimum of 3 laps in the car to be raced, and in the correct session, in order to qualify (MOTORSPORT UK Regulations Q4.5).
3. At Double Header Meetings the Grid for Race 2 will be set by second fastest practice times.

4. RACES: Should any race be disrupted the Clerk of the Course shall not be obliged to resume or rerun the race ((Q)5.4.) (1.6.4. above applies)

5. STARTS:

1. All cars will be released to form up on the grid prior to the start in formation as specified on the grid sheet.
2. The start will be via Standing start. The minimum Countdown procedures/audible warnings sequence shall be:-
 - I. 1 minute to start of Green Flag/Pace Lap - Start Engines/Clear Grid.
 - II. 30 Seconds - Visible and audible warning for start of Green Flag/Pace Lap.
 - III. A five second board will be used to indicate that the grid is complete.
 - IV. The red lights will be switched on five seconds after the board is withdrawn.
3. Any car removed from the grid after the 1 minute stage or driven into the pits on the Green Flag lap shall be held in the pitlane and may start the race after the last car has passed the startline or pitlane exit, whichever is the later to take the start from the grid.
4. Any driver unable to start the Green Flag/Pace lap or start are required to indicate their situation as per MOTORSPORT UK Regulation (Q)12.13.2. In addition any driver unable to maintain grid positions on the Green Flag Lap, to the extent that ALL other cars are ahead of them, may complete the Green Flag lap but MUST remain at the rear of the last row of the grid but ahead of any cars to be started with a time delay.
5. In the event of any starting lights failure the Starter will revert to use of the National Flag.

6. SESSION RED FLAG: Should the need arise to stop any race or practice, RED LIGHTS will be switched on at the Startline and RED FLAGS will be displayed at the Startline and at all Marshals Signalling Points around the Circuit. This is the signal for all drivers to cease circulating at racing speeds, to slow to a safe and reasonable pace and to return to the pit lane, during practice, and to the starting grid area, during a race, unless otherwise directed by officials. Cars may not enter the Pits unless directed to do so. Work on cars already in the Pits must cease when a race is stopped.

7. PITS, PADDOCK & PITLANE SAFETY:

1. Pits & Paddock: Competitors must ensure that the MOTORSPORT UK, Circuit Management and Organising Club Safety Regulations are complied with at all times.
2. Pitlane: The outer lane or lanes are to be kept unobstructed to allow safe passage of cars at all times. The onus shall be on all Drivers to take all due care and respect the pit lane speed limits.
3. Refuelling: May only be carried out in accordance with the MOTORSPORT UK General Regulations, the Organising Club Regulations, Circuit Management Regulations and the SRs or Final Instructions issued for each Circuit/Meeting.
4. Speed Limit: Pit Lane Speed Limit will be 60 km/h.

8. RACE FINISHES: After taking the Chequered Flag drivers are required to:

- I. progressively and safely slow down
- II. remain behind any competitors ahead of them,
- III. return to the Pit Lane Entrance/Paddock Entrance as instructed,

- IV. comply with any directions given by Marshals or Officials
- V. keep their helmets on and harnesses done up while on the circuit or in the pitlane.

9. RESULTS: All Practice Timesheets, Grids, Race Results are to be deemed Provisional until all vehicles are released by Scrutineers after Post Practice/Race Scrutineering and/or after completion of any Judicial or Technical Procedures. (MOTORSPORT UK regulation (D)26.3.)

10. TIMING MODULES: The 750 Motor Club utilises AMB transponder-based timing and competitors must have a compatible transponder fitted and working and advise the race organisers of its number prior to the event. The transponder is a TRANX 260 Direct Powered and is available from HS Sports Ltd – 01260 275708.

11. QUALIFICATION RACES: If any event is oversubscribed the Organising Club may at their discretion run Qualification Races.

13. ONBOARD CAMERAS:- All competitors are required to carry an on board in car camera with a wide angle lens that records to an SD card in a minimum resolution of 720p. Footage from the cameras may be used where there is an incident which is subsequently brought before the Clerk of the Course for investigation. The decision to review any such video footage is at the discretion of the Clerk of the Course, the Stewards of the Meeting, the Championship Stewards or the Championship organisers.

- (i) It is the competitor's sole responsibility to ensure safe installation and effective operation of the camera equipment. At all times cameras must be fitted in accordance with MOTORSPORT UK Regulations and be approved by the Chief Scrutineer in accordance with J.5.20.5
- (ii) Cameras must be mounted in a central to left position with the steering wheel and front windscreen in clear view
- (iii) In the event that no data is available on request (other than due to a proven defect with the equipment) sanctions may be applied which can include a 5 place grid penalty if footage is not available after practice. In the event of footage not being available after a race sanctions can include time penalties, exclusion from the results and exclusion from the meeting. The burden of proof to establish the cause of any failure will lie with the competitor.

3: SPECIFIC CHAMPIONSHIP REGULATIONS

In the event of any rounds being oversubscribed the Organising Club may, in liaison with the Championship Coordinator, at their discretion run Qualification races as per 2.11 of these regulations. Alternatively at double header race meetings, should there be sufficient space within the timetable, the Organising Club may divide the grid after qualifying into 3 separate Groups. The Groups will then form 3 races whereby each competitor participates in two races. All 3 races will be eligible for full championship points.

At each Round of the championship Race 1 grid positions will be determined by each competitors fastest lap time in Qualifying. At double header meetings, the grid positions for Race 2 will be determined by the competitors second fastest lap time in Qualifying.

4: SPECIFIC CHAMPIONSHIP PENALTIES:

In accordance with Section C of the current MOTORSPORT UK Yearbook

4.1: INFRINGEMENT OF TECHNICAL REGULATIONS:

1. Arising from post practice Scrutineering or Judicial Action:
Minimum Penalty: The provisions of MOTORSPORT UK Regulations: C3.3.
2. Arising from post-race Scrutineering or Judicial Action: Minimum Penalty: The provisions of MOTORSPORT UK Regulations: C3.5.1 (a) and (b).



For infringements deemed to be of a more serious nature the Clerk of the Course will invoke the provisions of Regulation C3.5.1 (c).

4.2: ADDITIONAL SPECIFIC CHAMPIONSHIP PENALTIES:

1. In the case of a driver being excluded from a race, the Clerk of Course will impose the penalties set out in MOTORSPORT UK Regulation C3.5.1 a & b and may impose the penalty set out in MOTORSPORT UK Regulation C3.5.1 c.
2. In order to maintain standards of conduct, the Championship Organisers will monitor all Officials/Observers reports of adverse behaviour at race meetings. If any individual is included on two such reports during one racing season the Championship Organisers will request the Clerk of Course at future race meetings to consider specific observation of that driver's conduct.
3. The Clerk of Course may impose a "Stop-Go" or "Drive through" penalty during a race in accordance with MOTORSPORT UK Regulation Q.12.6.
4. Any Competitor who is penalized under the Championship Sporting Regulations at any stage of a Championship event and receives an allocation of penalty points on their race license in accordance with MSA Regulations, will receive a Championship points deduction equal to the number of penalty points which were allocated. Should the same competitor receive penalty points at another round of the Championship then the number of Championship points deducted will be double the number of penalty points applied. If penalty points are applied at a third round, then the Championship points deducted will be triple this number, and quadrupled at the fourth occurrence of such a penalty etc. This may result in a driver receiving a negative score.
5. Championship Stewards are also empowered to consider any request from the Championship co-ordinator to penalize any Competitor for any breach of Championship regulations and, after holding a formal hearing if they deem it necessary, to impose a penalty in accordance with MOTORSPORT UK Regulation C.2.1.1 (subject to the rights of appeal provided for in Section C.)
6. One or more of the following may be imposed by the Championship Stewards as appropriate:
 - a) Reprimand
 - b) Fine. This may be also applied in the case of a driver receiving three reprimands from the Championship Stewards in one season.
 - c) Time or Grid Penalties
 - d) Suspension from all or part of the Championship. This may also be applied in the case of a driver receiving two fines from the Championship Stewards in one season.

5: TECHNICAL REGULATIONS

5.1: INTRODUCTION:

The following Technical Regulations are set out in accordance with the MOTORSPORT UK specified format and it should be clearly understood that if the following texts do not clearly specify that you can do it, you must work on the principle that you cannot. The fact that some modifications are mentioned as prohibited does not imply that others are allowed. The Locost Championship is not a Development Formula.

A) STANDARD: The word 'standard' used within these technical regulations as a description of components is to be interpreted as per 'Standard Part' defined in Section B – Nomenclature & definitions in the MOTORSPORT UK Blue Book. Checking will be by comparison to spare parts supplied by the manufacturer's official agent or by any other means necessary to ensure compliance.

B) STANDARD PATTERN: The phrase 'standard pattern' used within these technical regulations as a description of components is to be interpreted as per 'Standard Part' defined in Section B – Nomenclature & definitions in the MOTORSPORT UK Blue Book. Checking will be by comparison to spare parts supplied by the manufacturer's official agent or by any other means necessary to ensure compliance.

5.2: GENERAL DESCRIPTION:

The **LOCOST CHAMPIONSHIP** is for Competitors participating in cars built to these regulations and specifications outlined in the book "Build Your Own Sports Car" written by Ron Champion. All cars will run in one class.

5.3: SAFETY REQUIREMENTS:

All cars must comply with the technical regulations listed in the MOTORSPORT UK Year Book sections J & Q, and with the safety requirements listed in section K. Rollcage: A six-point cage as per Diagram 1 in appendix 6 of these regulations, with reference to K1.6.1, is compulsory; optional reinforcing members such as those detailed in MOTORSPORT UK Year Book section K Drawing 12 may be fitted but none may extend forward of the front roll hoop; a diagonal brace/s within the top of the rollcage as per section K drawing 10 is recommended. Side-intrusion bars are strongly recommended to be fitted external to the chassis but may not extend further forward than the front of the driver footwell; they should be constructed using tubes of the same material and dimensions as the main cage and should be fitted by a roll cage manufacturer. Particular care should be taken in selecting the mounting positions for the 'feet' of the cage, with reference to MOTORSPORT UK Year Book section K drawings 13 to 20. It is important that the roll cage is attached to the vehicle in such a way as to distribute the forces over the largest possible surface. It is not sufficient to attach the cage to a tube which is not supported vertically. Cages should be designed to form extensions to the chassis itself and not merely as attached components. Extinguishers must comply with MOTORSPORT UK regulation K 3.1.2 a). Seat belts must be FIA homologated and as per K2.1.2, 2.1.3. or 2.1.4. Further reference should be made to K5 – K6 and K8 – K14.

Cars with cages that do not comply with the technical regulations listed in the current MOTORSPORT UK Year Book sections J & Q and with the safety requirements listed in section K; must be in possession of a valid ROPS certificate and display the manufacturers identification.

5.4: GENERAL TECHNICAL REQUIREMENTS & EXCEPTIONS:

All cars must comply with the requirements of sections J and Q19 of the current MOTORSPORT UK Yearbook. All vehicles must comply with MOT requirements (with the exception of front headlights, front & rear side lights and front & rear indicators, rear reflectors, horn, emissions & rear fog light), be of sound construction and mechanical condition and be well maintained. Cars must be presented to a high standard. Unrepaired damage or cars not achieving a satisfactory level of preparation as judged by the championship scrutineers may receive a warning and may ultimately result in exclusion. Presentation of a vehicle for scrutineering is a declaration by the entrant/driver that the vehicle is eligible for that event and fully complies with the championship regulations. There is no requirement for an MOT Certificate, Road Tax or Insurance. As a minimum, two mirrors must be fitted, each with a minimum surface area of 50 sq. cms and giving a clear view to the rear, one on each side of the centreline of the vehicle.

5.5: CHASSIS:

Chassis must remain identical to original in terms of material construction and dimensions. However, it is permitted to add an engine bay diagonal (line A) to mirror that on the driver's side and two bracing bars (lines B & C) between the cockpit sides and the junction of the dashboard top/transmission tunnel as per the drawings in Appendix 6 of these regulations; a permitted alternative rear bulkhead drawing is also shown in Appendix 6. It is also permitted to add a transverse bracing tube to the lower chassis in the footwell area as per the drawings in Appendix 6. **It is also permitted to retain chassis members C & B1 uncut as per the drawings in Appendix 6.** Towing Eyes with a minimum internal

diameter of 60mm, as detailed in Q19.1.3 must be fitted, front & rear, no higher than 18" from ground level; any metal portion of the towing eyes must be within the overall periphery of the vehicle and may be extended by means of a suitable flexible strap. A propshaft restraint must be fitted in accordance with MOTORSPORT UK regulation K12. The area below the cockpit must have a steel floor of at least 18swg/1.2mm which must be substantially welded to the chassis as per Diagram 6 in the Appendix to these regulations. The area immediately beneath the fuel tank may be under-skinned with aluminium. Aluminium under-skinning of the sides of the engine bay as shown in the drawings in Appendix 6 is permitted within the plan profile of the chassis and may not be extended beyond that profile. There must be drainage holes to prevent the accumulation of liquids. No edges of any part of any under-skinning may extend downwards beyond the silhouette of the chassis.

It is permitted to strengthen the steering rack mounts. It is recommended that all tube ends are sealed to prevent corrosion.

MATERIALS: Minimum thickness of:- chassis tubing = 16swg/1.5mm; steel floor = 18swg/1.2mm; aluminium panelling = 18swg/1.2mm. It is permitted to panel the transmission tunnel in 16/18swg aluminium as an alternative to steel. Spacing of rivets is free.

5.6: BODYWORK:

Front and Rear Wings Material: Fibreglass traditional style as shown in photo in section 6 of these regulations. Solid Surface with no aerodynamic devices either attached or moulded in. Rear Panel Material: Aluminium or glass fibre with solid surface. Scuttle Material: Fibreglass, aluminium or steel. Bonnet Material: Aluminium or fibreglass. Nose cone Material: Fibreglass. Side Panels Material: Aluminium. The side panels must be fitted directly on to the chassis top and bottom side rails.

1. Modifications Permitted:

1. General: Bodywork must remain unaltered, subject to 5.6.1.4

2. Interior: Only a fire extinguisher, a battery, Handbrake Lever with Cable(s), additional ballast (Must be retained safely) and any rollbar bracing may impinge upon passenger space. It is permissible to remove interior trim and passenger seat. There must be a removable panel in the top of the driver's footwell which permits access for inspection of the brake pedal to master cylinder linkage.

3. Exterior: The engine and transmission must be fully enclosed. Air filters may protrude through the bonnet without the need for any cover but must have an effective seal between them and the bonnet; any other holes in the upper surface of the bodywork forward of the steering wheel plus any holes in the side surfaces of the bodywork forward of the steering wheel above a longitudinal line joining the top of the front and rear wheel rims, must be covered with solid bodywork having only a forward facing opening, forward facing louvers or with a metallic gauze with a maximum hole size of 1mm; vents may be fitted in the side surfaces of the bodywork forward of the engine bay/passenger compartment bulkhead and below a longitudinal line joining the top of the front and rear wheel rims. These vents are restricted to being fitted into an aperture in the bodywork of a maximum surface area of 430sq cms per side. Any vents must have a maximum protrusion of 25mm, rearward facing or covered by gauze. Holes solely for the exhaust system do not require any cover/gauze but must be a reasonably close fit. All vehicles must be fitted with a windscreen or an aeroscreen of minimum vertical height, measured at its attachment to the bodywork, of 75mm and a minimum width of 250mm. The passenger space may be covered by a removable tonneau of soft flexible material, fitted no higher than the top edge of the bodywork. Soft-tops/hoods do not have to comply with silhouette ruling (4). Any car fitted with a soft-top or hardtop will be considered

to be a closed car and must be fitted with a full width and height windscreen and rear screen. A front number plate or a solid mounting plate 525mm wide by 115mm high (\pm 5mm on both dimensions) mounted securely & permanently vertical at all times, under the front of the nosecone and complying with ride-height regulations is mandatory; competitors will be issued with championship decals to be affixed to the plate. For clarification of MOTORSPORT UK regulation J5.2.6, mudguards must present no sharp edges and cover the complete wheel (flange, tyre and rim) around a minimum arc of 120° measured from hub centre and must be a continuous surface of rigid material with no gaps holes slots or vents. The front edge of the mudguard must be ahead of the vertical hub centreline. The rear edge of the mudguard may not be more than 75mm above the hub horizontal centreline. (The Offside front Mudguard may have a flexible mud flap fitted for the sole purpose of deflecting water.)

4. Bodywork: Must remain unaltered with the exception of height of the scuttle and any "power bulge" fitted.

5. Ground Clearance: Under no circumstance can any part of the bodywork, or of the suspended part of the car with the exception of the exhaust system, the sump and the bellhousing, be below a horizontal plane passing 75mm (50mm for the exhaust system, the sump and the bellhousing) above the ground, the car being in normal racing trim with the driver aboard. A gauge of 75mm or 50mm may be used by Scrutineers before or after races or practice to check the ground clearance. It is permitted to add shims to or modify the engine mountings in order to comply with these minimum heights. There is no minus tolerance to these measurements.

2. Modifications Prohibited:

1. General: Kevlar, carbon fibre and titanium materials are not permitted.

2. Interior. It is not permitted to mount the fuel tank/s within the passenger space.

3. Exterior: Aerofoils, spoilers and side pods are not permitted. No adjustable aerodynamic devices are permitted. Wheel arch extensions are not permitted. 'Under-skinning' of the chassis is prohibited with the exception of the cockpit area as per the plans and 5.5, and the area immediately beneath the fuel tank, fuel pump & fuel lines within the 'boot' space.

4. Bodywork: Modifications to the bodywork which the organisers or scrutineers deem may give an aerodynamic advantage are prohibited:

5. Ground Clearance: Side skirts or bridging devices are not permitted.

5.7: ENGINE:

Engine Sealing

All engines must have provision for scrutineer's wire seals. 1/16th (1.5mm) diameter holes pre-drilled in readily accessible locations on installed engines must be available.

- Sump to Block: Two adjacent retaining bolts on each side of the engine must be cross drilled.
- Rocker Cover: One retaining screw on each side of the engine must be cross drilled.
- Timing Cover to Block: Two adjacent retaining bolts must be cross drilled.
- Inlet Manifold to Head: Two adjacent retaining bolts must be cross drilled.
- Bellhousing to Block: Two adjacent retaining bolts must be cross drilled to enable the clutch and flywheel to be adequately sealed. OR Competitors must be prepared to remove either engine or transmission to enable sealing of clutch and flywheel in which case two adjacent clutch cover retaining bolts must be cross drilled.

Failure to comply renders the engine illegal.



General:

The addition of any material be it metal, plastic or composite etc. by any means be it welding, bonding, encapsulation or encasement to any component is prohibited (unless otherwise stated in these regulations). However specific repair to the mounting points of the cylinder block to the transmission or chassis is allowed, other casting repair may be allowed with prior written approval from the class scrutineer.

The use of thread locking compounds is permitted.

Specification of Main Components:

Unless stated to the contrary within this section, all parts used must comply with the definition of Standard or Standard Pattern (5.1.A or B of these regulations).

Cylinder block: Only a FoMoCo (Ford Motor Company) cast iron 1300 X flow cylinder block may be used; cast iron bearing caps must be retained; standard bolts must be used. AX type blocks are not permitted. The block height must measure at least 180.75mm.

Pistons: Pistons must be AE Part No: AE18647 (up to + 0.090") to either of the forms and dimensions shown in the illustrations in section 6 of these regulations. Whichever form is used, all the dimensions must be from the same illustration. Later type Nural pistons Part No's: (+0.020") 87-780607/00, (+0.030") 87-780609/00, (+0.060) 87-780614/00, (+0.090") 87-780617/00 may also be used. The dimensions of Nural pistons must be checked using the left hand column of the figures in section 6 of these regulations. Depth of bowl at centre is 13.87mm +/- 0.1mm. NOTE Piston Dimensions must be checked because of variations in batch production. Machining of the combustion chamber may be required to comply with the dimensions in section 6. Any sharp edges in the piston combustion chamber may be deburred to help prevent detonation/ preignition. Piston rings and gudgeon pin must be standard for those pistons. All rings must be fitted and the gudgeon pin may not be modified. Pistons may not protrude above block face.

Crankshaft: A FoMoCo 1300 Xflow 5-bearing crankshaft must be used of a stroke of 62.99mm

Connecting rods: FoMoCo 1300 Xflow conrods must be used.

Cylinder head: A FoMoCo 1300 Xflow cylinder head casting (as illustrated in section 6) must be used.

Valves & valve train: Standard or standard pattern valves with 3 collet grooves must be fitted; valves may not protrude more than 1.2mm above the head face. Maximum valve sizes are Inlet 1.506", Exhaust 1.24". The underhead radius of the inlet valve must be a minimum of 11.5mm; a radius checking gauge will be used which must only contact the valve at one point. The combustion chamber face of the valve heads may be flat or concave only. Valve seat angle must remain at 45° and be at least 0.060" wide. Overall length: inlet 110.92 ± 0.5mm; exhaust 110.61 ± 0.5mm. Valve stem oil seals are optional. Standard length 1100 or 1300 Xflow pushrods must be used. Valve springs are free but must be of single coil type. Spring caps must be the standard FoMoCo items. FoMoCo collets must be used.

Gasket: The cylinder head gasket must have a minimum compressed thickness of 0.85mm and a minimum cylinder aperture of 82.5mm.

Rocker assembly: Standard FoMoCo rocker pillars, rockers and rocker shaft must be used.

Camshaft: The only permitted camshaft is the Sky Ford Formula Ford camshaft. (Part number 91572456) This must remain entirely unmodified. It is not permitted to re-profile, re-grind or re-manufacture the camshafts. The camshafts must be purchased from Sky Ford. Sky Ford will supply a Formula Ford camshaft with individual recorded ID markings on the rear end face (It is recommended that followers are purchased at the same time). The 750 Motor Club reserves the right to remove the camshaft from any competitor's engine for the purposes of checking its authenticity. The Camshaft must conform to the dimensions for the Formula Ford Cam which can be found in the appendices of these regulations.

Sump & oil pump: Sump design is free and oil pick-up pipe may be modified. Dry sump lubrication is prohibited. A modified oil pump may be used but it must be mounted and operated as per the standard Ford fitment.

Flywheel & clutch: A FoMoCo 1100 or 1300 Xflow flywheel and ring-gear must be utilised. The minimum weight of flywheel and clutch assembly including flywheel and crankshaft mountings bolts is 10.5kg. Clutch driven plate must be a conventional single diaphragm spring type with shock absorber springs; friction material must be organic. A heavy-duty clutch cover may be used but must be the same configuration as the standard item.

1. Modifications Permitted:

It is the competitor's responsibility to ensure that no prohibited modifications have been carried out, if they are using an engine not assembled by them. Unless stated to the contrary within this section, all parts and/or replacement parts used must comply with the definition of Standard or Standard Pattern (5.1.A or B of these regulations).

Cylinder block: Maximum rebore is standard (81mm) +0.090" with an additional 0.008" wear allowance, using only the pistons detailed in 5.7 of these regulations. Core Plugs can be replaced and if necessary welded in place' to avoid leakage but no change to the water galleries are permitted.

Pistons: Balancing of pistons may only be carried out by removal of material below the gudgeon pin centreline and only 3 pistons may be adjusted.

Crankshaft: Balancing of the crankshaft is permitted by removal of material only from those areas specified for the purpose by FoMoCo. Tuftriding and shot peening is permitted. (Polishing of any surface other than bearing journals is not permitted)

Connecting rods: Balancing of conrods is permitted by removal of material only from those areas specified for the purpose by FoMoCo (i.e. the bosses on the big-end cap and on the little end); a maximum of three rods may be adjusted. Little end bushes may be replaced. Tuftriding and shot peening is permitted. Rod end bolts are free.

Cylinder head: It is permitted to fit valve seat inserts to allow the use of unleaded fuel. 3 angle valve seats are permitted; the 45° portion must be at least 0.060" width; maximum inside diameter on the port side of the inserts to be 33.5mm inlet and 28.09mm exhaust. Replacement valve guides may be fitted and may be either bronze or cast iron. Other than these modifications no material may be added to or removed from the cylinder head. Inlet and exhaust ports may not be modified in any way and must remain as cast.

Valves & valve train: It is permitted to fit shims below the valve springs.

Rocker assembly: Standard FoMoCo Xflow rockers may be refaced on their contact-pad but the radius must remain standard and the ratio must not exceed 1.54:1. Rocker spacing springs are free, but solid spacers are not permitted.

Camshaft: No modifications are permitted, however the use of offset dowels is permitted and the cam timing retention gears may be slotted to allow use of these offset dowels.

Sump & oil pump: Sump design is free and oil pick-up pipe may be modified. Dry sump lubrication is prohibited. A modified oil pump may be used but it must be mounted and operated as per the standard FoMoCo fitment.

Flywheel & clutch: A FoMoCo 1100 or 1300 Xflow flywheel and ring-gear must be utilised; to achieve balance and minimum weight material may be removed from the originally machined surfaces or the rim/flange only. The minimum weight of flywheel and clutch assembly including flywheel and crankshaft mountings bolts shall be 10.5kg. A heavy-duty clutch cover may be used but must be the same configuration as the standard item.

Ancillaries: Thermostat and thermostat housing is free. Crankshaft front pulley may be either standard FoMoCo pressed steel, standard Lotus twincam cast (Part No XO26E0331Y) or 4" steel.

2. Modifications Prohibited:



Any modifications other than those specifically permitted within 5.7 or 5.7.1 is prohibited. The fact that some modifications are mentioned as prohibited does not imply that others are allowed. It is specifically prohibited:-

- to add any material to the crankshaft by any means
 - to modify inlet or exhaust valves in any way
 - ceramic or anti-friction coatings are prohibited
- Vernier timing gears and duplex chains are prohibited, timing covers must remain unmodified.

Data-logging which requires the fitment or use of any additional sensors is prohibited; for the purposes of this regulation, GPS is not considered to be data-logging.

3. Location:

Front engine as detailed in original drawings. Relocation of the engine within the recognised engine bay is permitted provided no modifications are required to the original chassis or bulkhead. The engine must be mounted vertically in the chassis.

4. Oil/Water cooling:

Any system may be used for oil cooling provided radiators are within the periphery of the vehicle. Water must be cooled using a radiator positioned at the front of the chassis in the nose cone. Radiator construction is free, therefore can be all aluminium and of any thickness. The standard water pump and drive pulley must be retained; electric pumps are not permitted. **Water based coolant must be used.**

5. Induction Systems:

The inlet manifold must be as fitted as standard equipment by FoMoCo to any 1300 Kent engine. It must remain standard in every way shape and form, except for the matching of the inlet manifold port faces to the standard port faces of the cylinder head with a maximum intrusion into the manifold of 10mm. Manifold outlets (not those in the cylinder head) for Brake Vacuum and Water may be blocked by use of a metal bung / bolt or similar noting that the rectangular port to the head must be left clear for coolant to flow into / out of Manifold. Drilling of the Throttle linkage mounting threads and the fitting of suitable nut and bolts is permitted providing there is no intrusion into intake manifold. Any twin choke downdraught carburettor with one maximum 23mm choke and one maximum 24mm choke venturi may be used; the size of the carburettor jets are free. Simultaneously opening twin chokes are not permitted. Venturis must be integral to the carburettor; choke flaps and mechanisms may be removed. Carburettors may not be modified by the removal or addition of material. Press-fit fuel unions on the carburettor body must be replaced with screw-in unions. The carburettor must be fixed to the manifold using only the original fixings in their original positions. Air filters are free.

6. Exhaust systems:

Design and type of exhaust system including manifold and silencer is free, but must comply with MOTORSPORT UK noise restrictions as per MOTORSPORT UK yearbook J5.16.5 & J5.17. or as specified for any individual venue in the final instructions. As engines designed and manufactured before 31/12/99 catalytic converters are not required.

7. Ignition systems:

Mappable and programmable ignition systems are prohibited. Spark plugs and leads are free. The distributor must be the sole means of initiating the LT current to the coil and distributing the HT current and no additional electronic system or systems are permitted. The

distributor body is free and may contain either a contact breaker type system or a single pick-up housed within the body and amplifier.

8. Fuel delivery systems:

An electric fuel pump must be fitted. A fuel filter and/or pressure regulator may be fitted.

5.8: SUSPENSIONS:

1. Permitted modifications:

The original type of suspension system must be retained and should be: -

Front: Unequal length wishbones with suspension pick-up points to the dimensions in Diagram 3, Appendix 6 of these regulations. The bushes for the inboard end of the wishbone must be either bonded rubber (Metalastic type), or 'plastic' non metallic. Springing may be only by coil spring damper units (coil over dampers). No additional springing medium is permitted. Dampers constructed of steel or alloy (including the mounting eyes) with internal reservoirs may be used and if adjustable, only have a single adjustment. The longitudinal positioning of either the top or bottom front suspension pick-up points on the chassis may be adjusted to provide the correct caster, if required. Also the wishbone chassis brackets may be wider to allow caster adjustment. The upright and hubs must be from Ford Cortina Mk III, IV or V. An anti-roll bar may be fitted but must be one-piece and use only one link at either end to connect to the suspension.

Rear: Escort Mk1 or 2 live rear axle located by upper and lower trailing arms each side combined with a 'Panhard' rod. The chassis pick up points for the rear radius rods must retain the longitudinal position specified in the book but may be moved vertically to either 4.3" or 5.75" apart; it is recommended that the radius rods should be kept parallel. The bushes for the ends of the trailing arms must be either bonded rubber (Metalastic type) or plastic.

Springing may be only by coil spring damper units (coil over dampers), no additional springing medium is permitted, constructed of steel or alloy (including the mounting eyes) with internal reservoirs may be used and if adjustable, only have a single adjustment. For the Panhard Rod one "Rose-joint" may be used but only at one end. 'Plastic non metallic' suspension bushes may be used. The chassis bracket for the panhard rod may have an alternative vertical pick-up point. This is to allow the panhard rod to be parallel with the ground. An anti-roll bar may be fitted but must be one-piece and use only one link at either end to connect to the suspension.

2. Prohibited modifications:

No controls which could allow adjustment of anti-roll bars by the driver whilst normally seated are permitted. The use of spherical rod ends and rose joints is prohibited other than for one end of the 'Panhard' Rod and the anti-roll bar links. The use of anti-roll bars consisting of more than one torsion element is prohibited. Modifications to suspension pickup points other than those permitted in 5.8.1 are prohibited.

3. Wheelbase/track:

Wheelbase must be to the original dimensions. The maximum permitted track is 1610mm. This measurement is taken between the outer most point of each front tyre at the point where the tyre makes contact with the ground.

5.9: TRANSMISSIONS:



(Refer to 5.1 A & B) The gearbox must be of the 4-speed integral bellhousing type as used in the 1300cc rear wheel drive Escort, or any standard production gearbox as used in the Cortina Mk3, 4 or 5 range, or the 4 or 5 speed Ford Sierra Type 9 gearbox. Material may not be removed from the bellhousing, with the exception of the mandatory removal of the casting lump at the bottom front edge of the bellhousing. The differential must be from the Ford Cortina, Escort or Capri range of cars and must use a standard combination of crown wheel and pinion from one of those models. The bellhousing and differential housing must be cast iron. A small rectangular slot may be made in the Bellhousing to aid timing adjustment (Max 18mm x 50mm)

1. Permitted modifications:

A 'quick shift' gear linkage may be fitted.

2. Prohibited modifications:

Four wheel drive is not permitted. Rose joints or spherical rod ends are not permitted in any transmission locating linkages with the exception of that detailed in 5.8.1.

Transmissions & Drive ratios:

The gearbox and final drive ratios are free, but the gears must be genuine series-production FoMoCo parts; optional Ford Motorsport gear / final drive ratios or specialist competition transmissions including straight cut gears are not permitted and synchromesh must be retained. Maximum number of ratios 5, plus mandatory reverse. Autoselect gearboxes are not permitted. Limited slip, locked, torque-biasing differentials or similar are not permitted. (Refer also to 5.9 above).

It is not permitted to change any of the ratios from those originally fitted; it is not permitted to fit a non-standard set of ratios, even if all the ratios are taken from within the range of permitted gearboxes. A list of the gear ratios fitted to the permitted range of gearboxes is in Appendix 6.

5.10: ELECTRICS

1. Exterior Lighting: Brake warning lights must be operational and operated only by the brake pedal without a delay. Headlights if fitted must be a minimum diameter of 5¾". The front headlights, front and rear side lights and front and rear indicators may be removed as per MOTORSPORT UK J 5.14.3 & J 5.14.4.

2. Rear Warning Light: An LED rear fog light to EU regulation 7, an FIA homologated LED rear warning light, or an LED stop light to EU regulation 38 is mandatory and must be mounted directly to the rear or the underside of the rear roll hoop, within 10cms of the centreline of the vehicle. Any manufacturer fitted rear fog light must not be switched on unless it complies fully with this regulation.

3. Batteries: A battery and starter motor capable of repetitive starts must be fitted and operable by the driver whilst normally seated.

4. Generators: A fully working alternator/generator must be fitted and electrically connected so that the standard battery charging function is providing a charge to the onboard battery. The alternator/generator must be located in the standard position. Alternative mounting brackets may be used. The drive pulley must be steel.

5.11: BRAKES

A: Rear brakes must be FoMoCo drum brakes from a 'Kent' engined Cortina, Capri or Escort - disc brakes are prohibited. Brake lining material is free.

B: Front brakes must be standard Cortina cast iron callipers and solid (not ventilated) discs from a 'Kent' engined Escort, Cortina, Capri. Discs may not be cross-drilled, grooved or lightened in any way apart from resurfacing the friction face subject to a minimum thickness that must not be less than 11.0 mm. Pad material free, but carbon-fibre is prohibited. Brake hoses are free.

C: Handbrake must be fitted. It shall operate on both rear wheels and be capable of resisting movement (forwards and backwards) when tested by a Scrutineer on flat level dry surface.

1. Permitted Modifications:

The friction faces of the disc may be reclaimed by simple machining maintaining a minimum disc thickness of 11.00 mm. The friction face of the brake drum may be reclaimed by simple machining within manufacturer's repair tolerances. Pedal box and master cylinder/s are free. Adjustable bias valve may be fitted, provided it is located outside the cockpit. Brake bias adjuster may not be within the reach of the driver whilst normally seated.

2. Prohibited Modifications:

ABS systems are prohibited. An hydraulically-operated handbrake is not permitted in that it does not comply with MOT requirements. The use of discs which are grooved, cross-drilled, radially drilled or modified in any other way is not permitted, except for the machining of the friction faces as specified in 5.11.1. No modification may be made to the non-friction area of the disc/bell. The use of brake drums which are modified in any way other than that permitted in 5.11.1 is prohibited.

5.12: WHEELS / STEERING

1. Permitted Options: Steering rack must be from a Ford Escort Mk1 or Mk2; ratio of the rack is free. Steering rack mounts may be strengthened and rubber bushes replaced with different materials. Steering arm extensions are not permitted.

2. Prohibited Options. No other modifications are permitted including the fitment of any 'wheel trims' or similar air deflectors.

3. Construction & Materials: WHEELS: Steel or **one piece** aluminium-alloy.

4. Dimensions: Maximum width 6". Diameter 13".

5.13: TYRES

1. Specifications: The only permitted tyre is the Yokohama A539 sized at 185/60 x 13. No alteration to the tyre from the manufacturer's specification is permitted. Re-cutting, re-grooving or in any other way modifying the tread pattern is not permitted. All the manufacturer's data must be clearly visible. Buffing of sidewalls to remove data is prohibited. Tyres must be to MOT requirements in every respect. The use of tyre heating/heat retention devices, tyre treatments and compounds is prohibited.

2. Nominated Manufacturers: Yokohama

5.14: VEHICLE WEIGHT:

Minimum weight including driver and race overalls, helmet etc. is 615 kilos.

5.15: FUEL TANK / FUEL

1. Types: Fuel tanks are free but safety tanks are recommended. A non-return valve must be incorporated in the vent system.

2. Locations: Free within the area behind the rear bulkhead. Chassis or bulkhead may not be modified to allow fitment of the tank (it is recommended fuel tanks are not mounted directly to the aluminium rear bulkhead panel as this may contravene Q19.1.1 The

exception to this is to allow the addition of brackets to the chassis for the mounting of the fuel tank. On safety grounds none of the fuel filler pipework, the filler cap or associated fittings may be attached to the external bodywork.

3. Fuel: Only petrol as defined in Section B Nomenclature & Definitions, Pump Fuel a) section of the MOTORSPORT UK Yearbook for the current year and complying with BSEN228 may be used; fuel which exceeds the stated RON (max) levels in Appendix 1 of Section B Nomenclature & Definitions is prohibited even if it is sold/promoted as being legal for UK Competition and/or obtainable from 'roadside' pumps. The use of additives by competitors which boost the octane rating (RON) in any petrol is prohibited. At the end of practice and the race at least 3 litres of petrol from the tank of the competing car must be available to the scrutineers for analysis. Compliance with minimum weight for the car will be taken before the petrol is removed.

All vehicles must comply with the relevant maximum noise limits set out in MOTORSPORT UK Blue Book regulation J. Chart 5.18.

5.17: NUMBERS & CHAMPIONSHIP DECALS

1. Positions: Race numbers must be displayed on each side of the vehicle alongside the cockpit/driver and as far forward on the front of the vehicle as possible. 750 Motor Club decals must be affixed prominently near all number backgrounds. Championship Sponsor's decals (where applicable) must be affixed in or near the positions detailed on any diagram supplied with those decals. No decals may be affixed to the aeroscreen. 750 Motor Club and Championship Sponsor's decals must take preference to any other decals. Failure to comply will render the vehicle and driver ineligible to race.

2. Suppliers: Sponsors and Club decals will be available at the first championship race in which the vehicle is entered.

5.16: SILENCING:

6. APPENDICES:

Diagram 1 – ROPS guidance notes if no ROPS certificate exists for a given cage design.

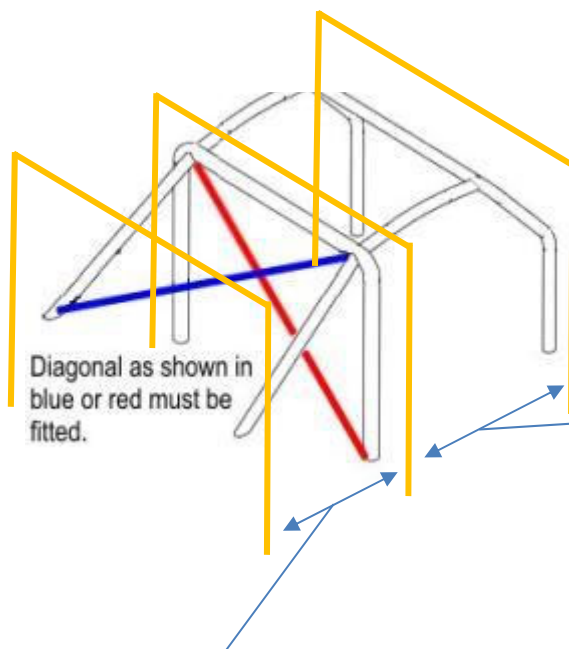

Front section of Roll cage not covered by ROPS but is a mandatory requirement for class regulations.
 Tube sizes (Including side impact bar(s)) to be diameter 38mm x 2.5 (1.5" x 0.095") or 40mm x 2.0 (1.6" x 0.083") or larger.
 (See MSA Blue Book Section K for Material specification and further details)

Note:- For any MSA ROPS Certified systems please ensure Valid Certification for the class (e.g. Locost) and Certificate label attached in correct position as defined by the ROP's Certification documentation.

Rear section of Roll cage must meet MSA Regulations (See Section K)
 Tube to be diameter 45mm x 2.5 (1.75" x 0.095") or 50mm x 2.0 (2.0" x 0.083")
 Rear stays at 30 degrees to the vertical, with steel reinforcement plate at least 3mm thick and of at least 120cm² area at the point of attachment to the chassis.
 (See MSA Blue Book Section K for Material specification and further details)

Contact 750MC Chief Scrutineer for any clarification on MSA ROPS requirements

Diagram 2

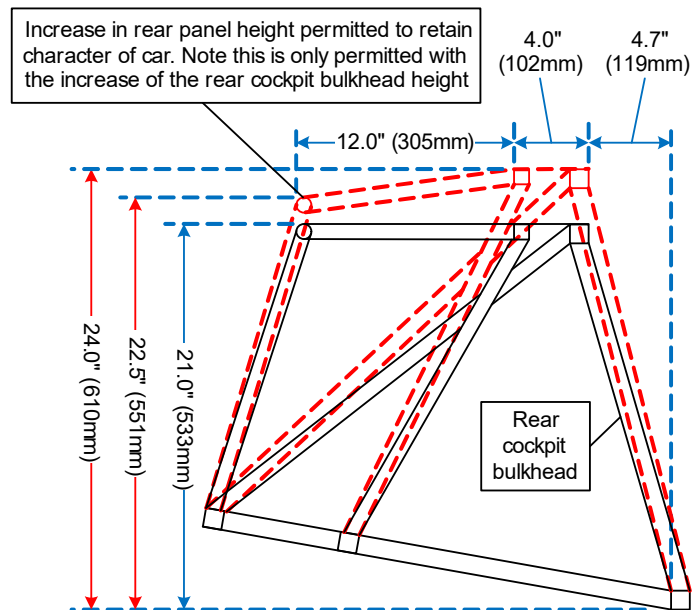

To achieve SVA Compliant Upper Seat Belt mountings it is permitted to increase the height of the rear cockpit bulkhead.

Standard shown —
 Maximum alternative height shown - - -

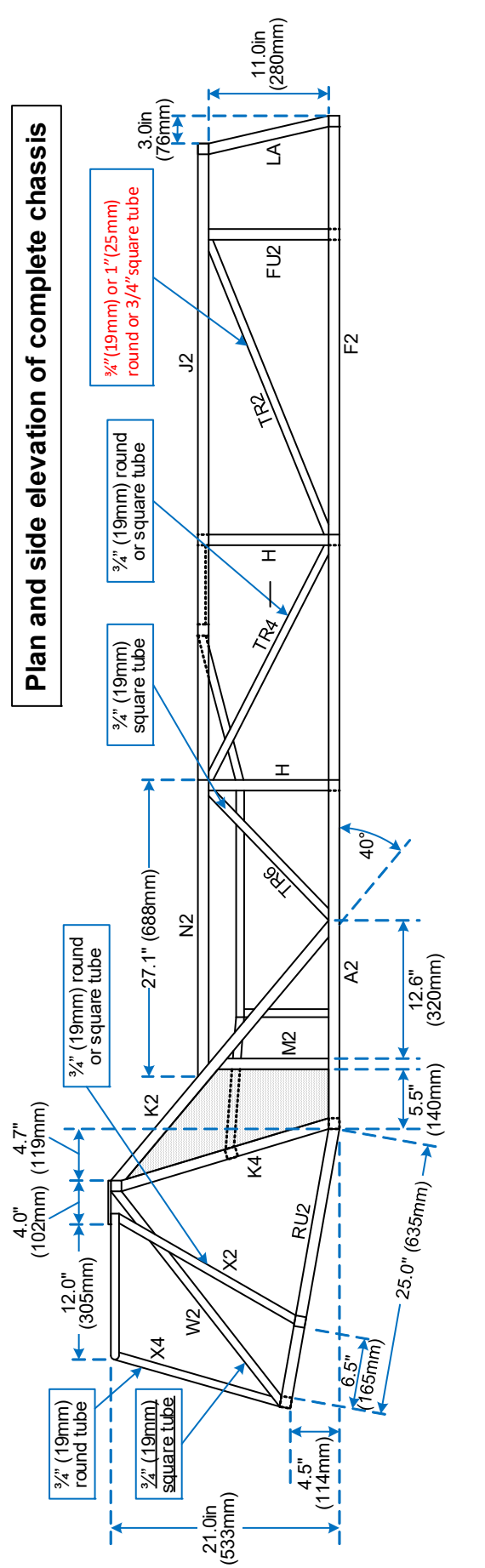
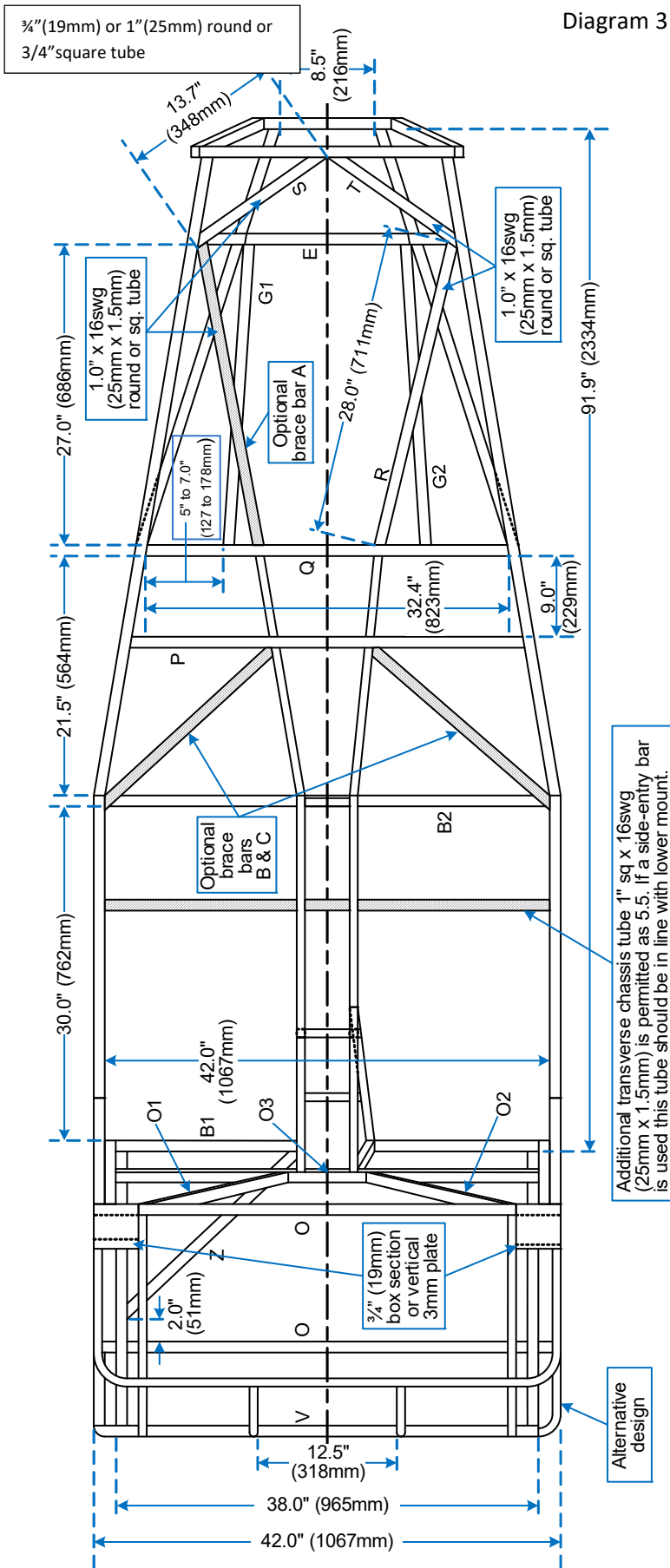
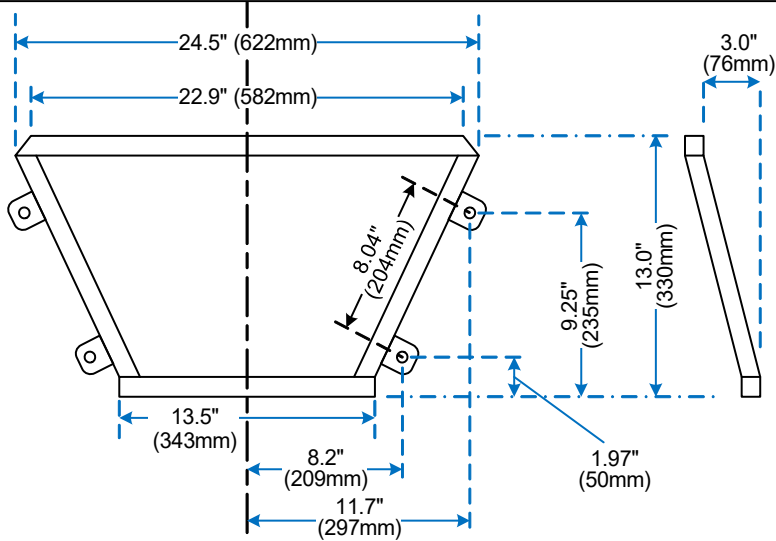

Diagram 4

Top drawing is Front chassis frame and location of the suspension mounting brackets (As standard).
 Alternative dimensions for the suspension mounting brackets may be used but must conform to the dimensions shown in the lower diagram.
 (Tolerance $\pm 15\text{mm}$ unless otherwise stated on drawings)



A: Inner lower pickup to underside of Chassis $65\text{mm} \pm 20\text{mm}$
 B: Inner upper pickup to underside of Chassis $245\text{mm} \pm 20\text{mm}$
 Distance between:-
 C: Inner lower pickups $420\text{mm} \pm 40\text{mm}$
 D: Inner upper pickups $600\text{mm} \pm 40\text{mm}$

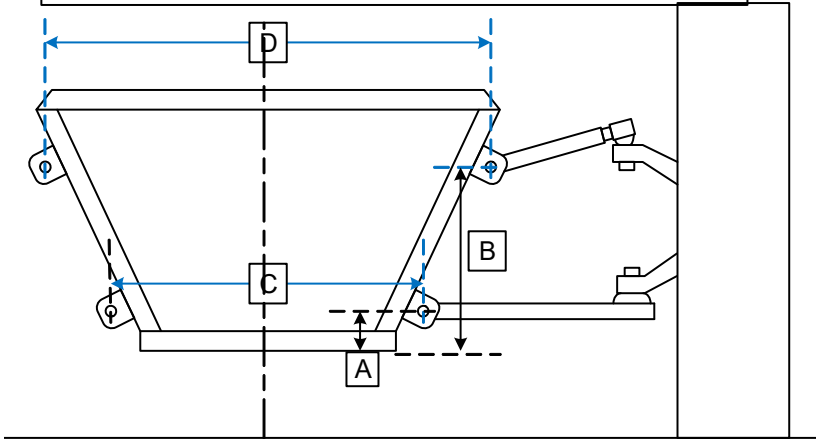

Diagram 5

Position of rear suspension mounting brackets
 (Positioning tolerance +/- 5mm)

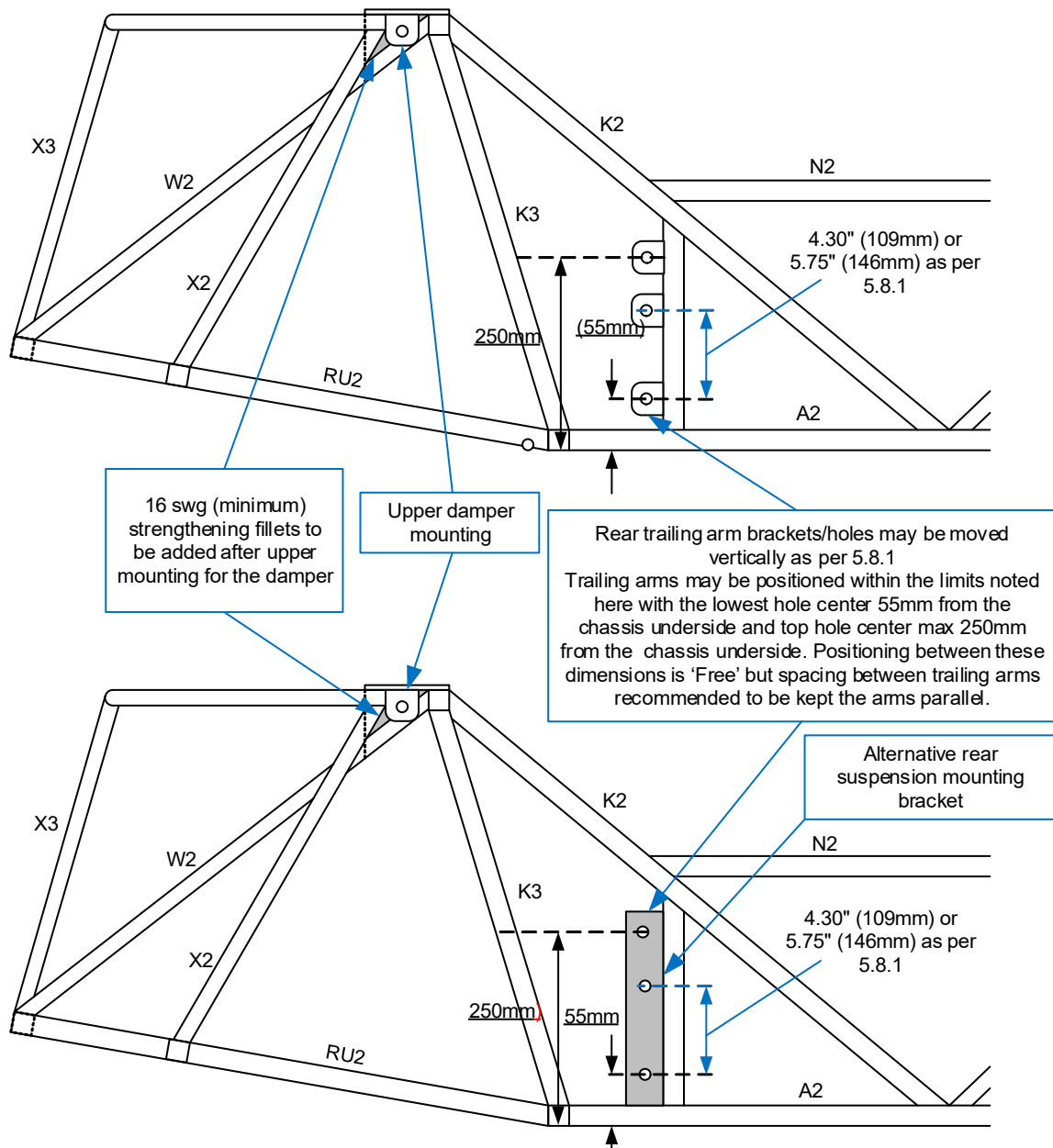
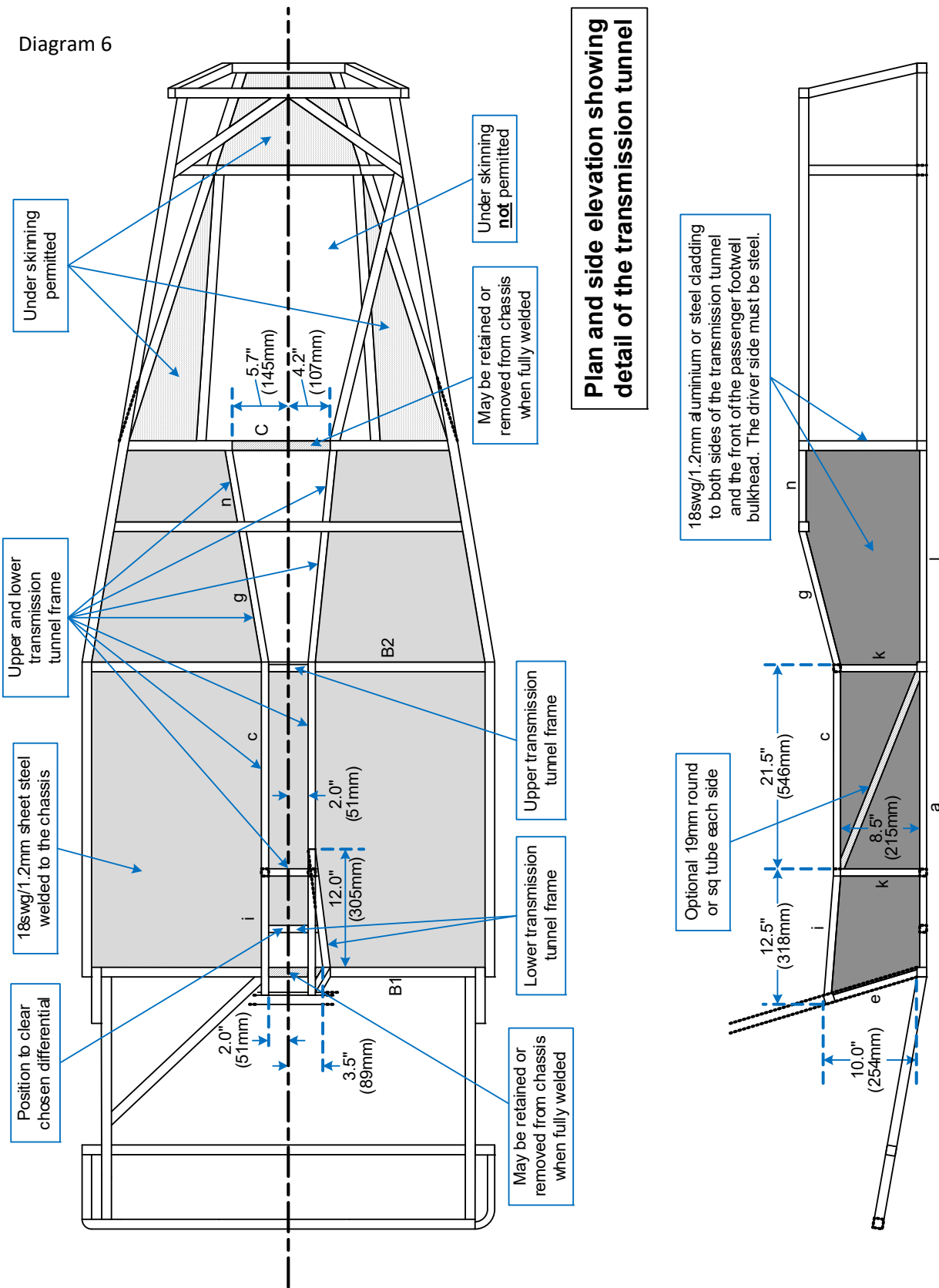

Diagram 6



Alternative Piston forms and dimensions – all dimensions are in mm.

Marking on top of Piston	Æ18647 (+ rebore)	Æ18647 + .090" 83.206
Gudgeon Pin to Top of Piston (Compression height)	44.08	44.25
Depth of Bowl at start of outer radius	14.48	To be machined to 13.87±0.1
Depth of Bowl at Centre	13.87	13.87±0.1
Corner Radius	R9.5 – 9.75	R9.5 – 9.75
Valve pocket depth	2.84	2.84
Overall piston height	83.80	83.82
Diameter of Bowl	53.80	53.80

Æ18647 + rebore

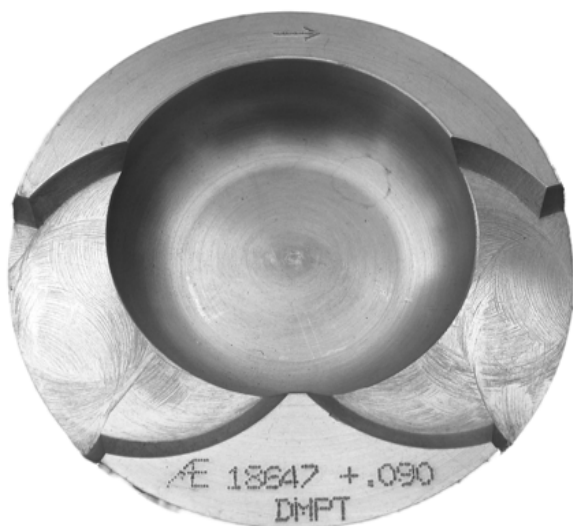

Æ18647 + .090" 83.206



Cylinder Head

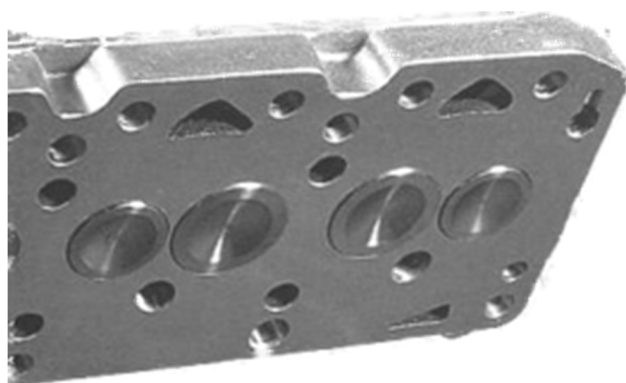

TABLE OF PERMITTED GEARBOXES AND GEAR RATIOS			
Fitted to		Escort Mk 1 & 2	
		Standard	Heavy Duty (GT)
		Cortina Mk3 1300 (OHC)	
		Early Sierra 1300 (OHC)	Early Sierra 1600 (OHC)
		Ratios	
Type 2	1st	3.656	3.337
	2nd	2.185	1.995
	3rd	1.425	1.418
	4th	1	1
	5th	N/A	N/A
	Rev	4.235	3.867

Fitted to		Cortina Mk2 & 3 1300, 1600 & 1600GT (OHV)	Early Sierra 2000 (OHC) & 2.3 V6
			Dash Change
		Ratios	
Type 3	1st	2.97	3.54
	2nd	2.01	2.4
	3rd	1.41	1.41
	4th	1	1
	5th	N/A	N/A
	Rev	3.32	3.96

Fitted to		Cortina Mk3, 4 & 5 1600, 1600GT & 2000 (GT) (OHC)	
		Sierra 2000 (OHC) & 2.3 V6	
		Ratios	
Type E	1st	3.65	
	2nd	1.97	
	3rd	1.37	
	4th	1	
	5th	N/A	
	Rev	3.32	

Fitted to		Sierra 1600,1800, 2000 (OHC) & 2.3 V6	Sierra 2.8 V6	Sierra 2.3 Diesel
		Ratios		
Type 9	1st	3.65	3.36	3.91
	2nd	1.97	1.81	2.32
	3rd	1.37	1.26	1.4
	4th	1	1	1
	5th	0.82	0.83	0.82
	Rev	3.66	3.36	3.66

The cam profile is defined by determination of lift (L-l) against a flat footed follower at various angles (θ).
 Maximum lift at all points on the camshaft must not be exceeded.

Standard Ford tolerances apply to the following camshaft drawing.

Dimension	Symmetrical Inlet	Exhaust
Lift at 0°	5.87mm	5.89mm
Lift at 5°	5.81mm	5.85mm
Lift at 10°	5.64mm	5.67mm
Lift at 15°	5.38mm	5.41mm
Lift at 20°	5.00mm	5.03mm
Lift at 30°	4.01mm	4.04mm
Lift at 40°	2.69mm	2.77mm
Lift at 60°	0.46mm	0.61mm
Lift at 90°	0.05mm	0.20mm

Angle between major axes of inlet and exhaust cams: 109°.

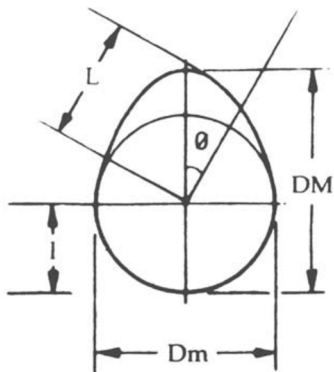

Front and Rear Wings